

DETAILS FOR CONVENTIONAL WOOD FRAME CONSTRUCTION



American Wood Council

**American
Forest &
Paper
Association**

TABLE OF CONTENTS

<i>Chapter/Title</i>	<i>Page</i>	<i>Chapter/Title</i>	<i>Page</i>
Introduction	3	Firestopping	8
General Scope	3	Draftstopping	8
Grade Marking	3	Exterior Wall Framing	8
Lumber Seasoning	4	Interior Partition Framing	9
TYPES OF FRAME CONSTRUCTION		Framing Around Chimneys and Fireplaces	9
Platform Frame	4	Roof and Ceiling Framing	10
Balloon Frame	5	Insulation and Vapor Retarders	11
Fastenings	5	Exterior Siding and Coverings	11
Plank and Beam Construction	5	Flooring	12
Truss-Framed Construction	5	Wood Decks	13
Foundations	5	Conclusion	14
Protection Against Termites and Decay	6	Appendix	52
Floor Framing	7		

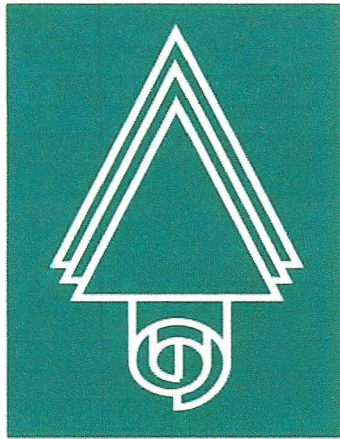
LIST OF TABLES

<i>Table</i>	<i>Page</i>
I. Nominal and Minimum-Dressed Sizes of Boards, Dimension and Timbers	15
II. Wood Shingle and Shake Weather Exposures	16

LIST OF ILLUSTRATIONS

<i>Figure</i>	<i>Page</i>	<i>Figure</i>	<i>Page</i>
1. Platform Frame Construction	17	35. Second Floor Overhang of Exterior Wall, Joists at Right Angles to Supporting Walls	33
2. Balloon Frame Construction	18	36. Second Floor Overhang of Exterior Wall, Joists Parallel to Supporting Walls	33
3. Methods of Loading Nails	18	37. Firestopping Around Pipes	34
4. Sizes of Common Wire Nails	19	38. Firestopping of Dropped Ceilings	34
5. Masonry Foundation Wall and Footing	20	39a. Firestopping of Masonry Walls - Floor	35
6a. Permanent Wood Foundation - Crawl space	20	39b. Firestopping of Masonry Walls - Ceiling	35
6b. Permanent Wood Foundation - Basement	21	40. Draftstopping of Trussed Floors	36
7a. Sump for Poorly Drained Soils	22	41. Multiple Studs at Corners	36
7b. Sump for Medium to Well Drained Soils	22	42. Wall Framing at Intersecting Partitions	36
8. Pier Foundation and Anchorage	23	43. Exterior Wall Openings, Header Details with Cripple Studs	37
9. Clearance Between Earth and Floor Framing	23	44. Exterior Wall Openings, Header Details with Joist Hangers	37
10. Support for Basement Post	23	45. Framing of Bay Window	38
11. Floor Framing at Exterior Wall	24	46. Wall Framing at Gable Ends	38
12. Girder Framing in Exterior Wall	24	47a. Wall and Floor Framing at Fireplace	39
13. Termite Shields	24	47b. Hearth Centering Detail	39
14. Anchorage of Sill to Foundation Wall	25	48a. Clearance of Fireplace Trim	40
15. Nailing Built-up Beams and Girders	25	48b. Section Through Mantle	40
16. Joist End Bearing	25	49. Building Paper and Siding Application	41
17. Joist Supported on Ledger	26	50. Application of Wood Shingles	41
18. Joist Supported by Metal Framing Anchors	26	51. Roof Framing Ceiling Joists Parallel to Rafters	42
19. Joists Resting on Girder	26	52. Roof Framing, Ceiling Joists Perpendicular to Rafters	42
20. Joists Resting on Steel Beam	26	53. Roof Framing Gable Overhang	43
21. Diagonal Bridging of Floor Joists	27	54. Flat Roof Framing	43
22. Solid Bridging of Floor Joists	27	55. Valley Rafter Roof Framing	44
23. Framing of Tail Joists on Ledger Strip	28	56. Hip Rafter Roof Framing	44
24. Framing of Tail Joists by Framing Anchors	28	57. Roof Framing at Eave	44
25. Framing of Header to Trimmer by Joist Hangers	28	58. Shed Dormer Roof Framing	45
26. Notching and Boring of Joists	28	59. Gable Dormer Framing	46
27. Framing Over Bearing Partition, Platform Construction	29	60. Roof Framing Around Chimney	46
28. Framing Over Bearing Partition, Balloon Construction	29	61. Roof Ventilation Requirements	47
29. Framing Under Non-Bearing Partition	30	62. Ventilating Eave Overhangs	47
30. Attachment of Non-Bearing Partition to Ceiling Framing	30	63. Wood Siding Patterns and Nailing	48
31. Interior Stairway Framing	31	64. Corner Treatments for Wood Siding	48
32. Stairway With a Landing	32	65. Application of Masonry Veneer to Wood Framing	49
33. Framing Supporting Bathtub	32	66. Wood Strip Flooring	49
34. Second Floor Framing, Exterior Wall	33	67. Wood Deck	50
		68. Ceiling-Floor Partition Separation	51

AF&PA®



AMERICAN
WOOD
COUNCIL®

Engineered and Traditional Wood Products

DETAILS FOR CONVENTIONAL WOOD FRAME CONSTRUCTION

INTRODUCTION

Wood frame construction is the predominant method of building homes and apartments in the United States, enabling this nation to have the world's best housed population.

Increasingly, wood framing is also being used in commercial and industrial buildings. Wood frame buildings are economical to build, heat and cool, and provide maximum comfort to occupants. Wood construction is readily adaptable to traditional, contemporary and the most futuristic building styles. Its architectural possibilities are limitless.

History has demonstrated the inherent strength and durability of wood frame buildings. The purpose of this document is to summarize and illustrate conventional construction rules as a guide for builders, carpentry foremen, building inspectors and students in the building trades. The application of conventional construction rules may be limited by building code requirements in use where the building is being constructed. Conventional construction provisions, as found in this publication, represent techniques with a history of satisfactory performance.

Today, some building codes may require a more rigorous structural design methodology than is associated with conventional construction. This requirement may result from a need for better building performance when the structure is exposed to moderate-to-high wind, seismic, and snow loads. AF&PA publishes the *Wood Frame Construction Manual for One- and Two-Family Dwellings* ([Appendix, Item 1](#)) to provide solutions based on engineering analysis, in accordance with recognized national codes and standards. Like conventional construction, the engineered solutions are provided in a prescriptive format.

GENERAL SCOPE

With any building material or product, sound construction and installation practices must be followed to assure durability and trouble-free performance. Areas for economy in basic design and house construction are covered in numerous publications. However, skimping on materials or using poor building practices in constructing the house frame saves little. Such practices may reduce the strength and rigidity of the structure and cause difficulty in attachment of cladding materials and trim. Therefore, the details in this document are not intended to be bare minimums; rather, they reflect requirements for producing sound, low maintenance wood frame buildings.

The first approach to achieving a strong, durable structure, involving economical use of materials, is to follow a basic modular plan for layout and attachment of framing members. Such methods use a 4-foot design module, which governs a 16-inch spacing of joists, studs, rafters and panel sheathing products. This module also provides for alternate 24-inch spacing of floor, wall and roof framing where floor and roof trusses are used, and accommodates 24-inch spacing of studs where wind loads permit, or where larger studs are required for thicker insulation or heavier floor and roof loads.

Terminology

Previous versions of this document have followed the practice of using "shall" and "should" to emphasize those mandatory instructions covering fire and life safety as separate from general good practices cover durability, reduced maintenance costs and best performance of products. Recognizing that the term "should," in practice, can be considered as optional and that failure to follow such provisions can result in serious damage or excessive maintenance costs to the home owner, this publication states the procedure as it is to be illustrated in the house plan, followed by the job foreman and subcontractors, and enforced by the building inspector.

Wherever possible, the provisions described are intended to conform to current code provisions; however, it is recommended that the local building code be checked for additional requirements. Other methods of building may provide equal, or possibly, improved performance. These, however, must provide performance assurance acceptable to the owner and the building inspector.

Dimensioning

In general, dimensions for framing lumber, wood siding and trim referenced in this document are nominal dimensions; i.e., 2x4, 2x6, etc., for simplicity. Actual surfaced dimensions conform with those in Product Standard PS 20, published by the American Lumber Standards Committee ([Appendix, Item 2](#)). A summary of these dimensions is set forth in [Table I](#).

GRADE MARKING

Framing lumber, also referred to as "dimension" lumber, must be properly grade marked to be acceptable under the major building codes. Such grade marks identify the grade, species or species group, seasoning condition at

time of manufacture, producing mill number and the grading rules writing agency.

The bending strength, F_b , and the stiffness or modulus of elasticity, E , may be determined from the grade mark for lumber used as joists, rafters, and decking. These values enable determination of allowable spans for the lumber.

Grading rules for various softwood and certain hardwood species are written by regional rules writing agencies, which operate within the system, established by the American Lumber Standards Committee (ALSC) under the authority of the U.S. Department of Commerce. This system provides for on-going inspection of lumber produced to the applicable rules and for monitoring of the inspection agencies by the Board of Review of the ALSC.

Engineering values and tables of allowable spans for framing lumber are available from the American Forest & Paper Association ([Appendix, Items 3 and 4](#)), and the regional rules writing agencies.

LUMBER SEASONING

Wood loses moisture from the time it is cut and manufactured into lumber until it reaches equilibrium in service. Best performance of wood frame buildings is obtained when the moisture content of framing lumber at the time the building is enclosed with sheathing and interior finish, is as close as possible to the condition it will reach in service.

Grading rules which conform with American Softwood Lumber Standard, PS 20, provide for framing lumber surfaced to standard sizes at the unseasoned condition (S-Grn), at 19 percent maximum moisture content (S-Dry) and at 15 percent maximum moisture content (KD) or (MC-15). Standard sizes apply to S-Dry (19% max), with slightly larger sizes provided for S-Grn so that both products reach approximately the same size after seasoning in service. MC-15 lumber is produced to the same standard size as S-Dry. In some cases engineering stress values assigned to lumber produced to different seasoning conditions are adjusted to reflect the effects of seasoning.

Lumber should be protected from weather at the job site. Buildings should be roofed and enclosed with sheathing without delay to maintain the original dryness of the lumber or to help unseasoned lumber reach equilibrium during construction.

TYPES OF FRAME CONSTRUCTION

PLATFORM FRAME

In platform-frame construction, first floor joists are completely covered with sub-flooring to form a platform upon which exterior walls and interior partitions are

erected. This is the type of construction most generally used in home building, [Figure 1](#).

Final moisture content of lumber in the building varies with the geographic region and with location in the structure. Floor joists over a crawl space may reach seasonal moisture contents in excess of 14 percent. Roof trusses and rafters, on the other hand, may dry below 6 percent. Squeaking floors and loose nails in wallboard or siding can be reduced by allowing framing to season to a moisture content which is as close as possible to moisture levels it will reach in service and by utilizing modern framing techniques and products, including glued-nailed floor systems, grooved or ring-shanked nails, and drywall screws.

Protection of Materials

Lumber, panel products and millwork (windows, doors and trim) should be protected from the weather when delivered at the building site. Preparation of a construction schedule will assure that lumber and millwork are delivered as needed. Follow these simple rules:

- (1) Support framing lumber, plywood and panel products at least six inches above ground and protect them below and above with a waterproof cover such as plastic film. Finish lumber and flooring, particularly, are to be protected from ground or concrete slab moisture and kept under cover – preferably indoors – until installation.
 - (2) Store door and window assemblies, siding and exterior trim inside. Where this is not practical, these materials are to be elevated from the ground and protected above and below with a weatherproof cover.
- Millwork items are often pre-treated with a water-repellent preservative as received. Whether treated or not, such materials are to be stored under cover. Untreated exterior millwork should receive a water-repellent preservative treatment before installation.
- (3) Store interior doors, trim, flooring and cabinetwork in the building. Where wet plaster is used it must be permitted to dry before interior woodwork, cabinetry and flooring are installed.

erected. This is the type of construction most generally used in home building, [Figure 1](#).

Platform construction is easy to erect. It provides a work surface at each floor level and is readily adapted to various methods of prefabrication. In platform systems it

is common practice to assemble wall framing on the floor and tilt the entire unit into place.

BALLOON FRAME

In balloon-frame construction, exterior wall studs continue through the first and second stories. First floor joists and exterior wall studs both bear on the anchored sill, **Figure 2**. Second-floor joists bear on a minimum 1x4-inch ribbon strip, which has been let-in to the inside edges of exterior wall studs.

In two-story buildings with brick or stone veneer exteriors, balloon framing reduces variations in settlement of framing and the masonry veneer. Where exterior walls are of solid masonry, balloon framing of interior bearing partitions also reduces distortions in door and closet openings in crosswalls. The requirement for longer studs, and the difficulty in accommodating current erection practices and firestopping, has reduced the popularity of this system.

FASTENINGS

Nails, used alone or in combination with metal framing anchors and construction adhesives, are the most common method of fastening 1- and 2-inch framing lumber and sheathing panels, **Figure 4**. Ring or spiral shank nails provide higher load-carrying capacities than common nails of the same diameter, and are particularly useful where greater withdrawal resistance is required.

Nailed joints provide best performance where the load acts at right angles to the nails. Nailed joints with the load applied parallel to the nail (in withdrawal) should be avoided wherever possible, since joints are weakest when nailed in this manner, **Figure 3**.

Where tilt-up wall framing is not practical, or where stronger stud-to-plate attachment is required (as in the use of rigid foam sheathing), toe-nailing is the most practical method of framing studs and plates.

In toe-nailing, nails are driven at a 30-degree angle (approximately) to the stud. Studs can be pre-drilled to simplify this operation and prevent excessive splitting.

PLANK AND BEAM CONSTRUCTION

In the plank and beam framing method, beams of adequate size to support floor and roof loads are spaced up to eight feet apart. Floors and roofs are covered with 2-inch planks. These serve as subflooring and roof sheathing, and, where tongue-and-grooved planking is used, provide an attractive finished floor and ceiling.

Ends of floor and roof beams are supported on posts which provide the wall framing. Supplementary framing between posts permits attachment of wall sheathing and

exterior sidings. Details for this method of framing are provided in *Plank and Beam Framing for Residential Buildings - Wood Construction Data No. 4*, published by the American Forest & Paper Association (**Appendix, Item 5**).

TRUSS-FRAMED CONSTRUCTION

The strength and resilience of wood construction is due to its framework of structural lumber combined with a covering of subflooring, wall and roof sheathing. Additional engineering of the system through use of floor and roof trusses and metal framing anchors provides even greater rigidity and permits wider spacing of floor and roof supporting members.

FOUNDATIONS

A firm foundation, consisting of properly installed footings of adequate size to support the structure, is essential to the satisfactory performance of all buildings. Such foundations fully utilize the strength and resilience of wood frame construction.

Footings should extend below exterior grade sufficiently to be free of frost action during winter months. Where roots of trees are removed during excavation or when building on filled ground, the ground should be well compacted before footings are installed or concrete is poured.

Where poor soil conditions exist, satisfactory foundations may be constructed of treated timber piles capped with wood or concrete sills. Footing requirements are covered in the local building code. It is good practice, generally, to make the footing thickness equal to the thickness of the foundation wall and the footing projection equal to one-half the foundation wall thickness.

Two principal foundation types are commonly used. These are concrete and pressure preservative treated wood. Concrete footings with poured concrete or masonry block foundation walls are most common. An increasingly popular foundation for houses and other wood frame buildings is the "Permanent Wood Foundation" which is accepted by all model building codes and the Department of Housing and Urban Development (HUD).

Concrete Foundations

Concrete footings are frequently unreinforced. Where unstable soil conditions exist, however, reinforced concrete is used. This requires engineering analysis of the footing. The foundation wall may be of poured concrete or masonry blocks. Masonry block basement walls typically have a ½-inch coat of Portland cement mortar applied to the exterior. When set, the mortar parging is covered with two coats of asphalt to resist penetration of the wall

by ground water, **Figure 5**. Masonry block walls are capped at the top with 4 inches of solid masonry or concrete. Drain tiles are installed around the entire footing perimeter of concrete foundations. These lead to a storm drain or sump with pump to a positive drain.

Wood Foundations

Permanent wood foundations are engineered systems consisting of wood framing and plywood sheathing that have been pressure treated with heavy concentrations of preservative to assure freedom from decay and insect attack. The system is used with both basement and crawl space foundations, **Figures 6a** and **6b**.

Permanent wood foundations are particularly suitable for cold weather construction where the entire foundation system can be prefabricated. The footing and basement area consists of a layer of gravel or crushed stone of 4-inch minimum thickness. Treated wood footing plates of adequate thickness and width are placed on the stone base at the wall perimeter. These support foundation stud walls of treated lumber framing and plywood sheathing which have been designed to support vertical and lateral loads. Exterior plywood joints are caulked and basement foundation walls are covered with 6-mil polyethylene film to direct ground water to the gravel base. Basement floors are concrete slab or wood flooring laid on treated wood joists on sleepers. A 6-mil polyethylene film is placed over the gravel base beneath the slab or wood floor.

Drain tiles are not required with permanent wood foundations. Ground water at the wall perimeter drains through the gravel footing and the gravel slab base to a sump which leads to a daylight outlet or is pumped to a storm drain, **Figure 7**. Such basements have a superior record for maintaining dry interior conditions. Additional information on Permanent Wood Foundations is available from AF&PA and the Southern Pine Council (**Appendix, Items 6** and **7**).

Other Foundations

Other foundation types include free standing piers, piers with curtain walls, or piers supporting grade beams. Piers and their footings must be of adequate size to carry the weight of the house, contents and occupants. Pier spacing will depend upon arrangement of floor framing and location of bearing walls and partitions. Spacing in the range of 8 to 12 feet is common practice, **Figure 8**.

PROTECTION AGAINST TERMITES AND DECAY

Good construction practice prevents conditions that could lead to decay or termite attack. Details for termite and decay prevention are found in *Design of Wood Structures*

for Permanence-Wood Construction Data No. 6 (**Appendix, Item 8**). The following practices are basic:

All roots and scraps of lumber are removed from the immediate vicinity of the house before backfilling.

Loose backfill is carefully tamped to reduce settlement around the foundation perimeter. Grading at the foundation and over the building site is sloped to provide drainage away from the structure.

Unexcavated Spaces

Exposed ground in crawl spaces and under porches or decks is covered with 6-mil polyethylene film. Minimum clearance between the ground and the bottom edge of beams or girders is at least twelve inches. Clearance between the bottom of wood joists or a structural plank floor and the ground is a minimum of 18 inches, **Figure 9**. Where it is not possible to maintain these clearances, approved¹ pressure treated or naturally durable wood species are used.

Columns and Posts

Posts or columns in basements and cellars, or exposed to the weather, are supported by concrete piers or pedestals projecting at least 1 inch above concrete floors or decks and 6 inches above exposed earth. Wood posts and columns are separated from concrete piers by an impervious moisture barrier, except when approved pressure treated or naturally durable wood species are used, **Figures 9** and **10**.

Wood posts or columns which are closer than 8 inches to exposed ground in crawl spaces or supporting porches or decks are of approved pressure treated or naturally durable wood species.

Exterior walls

Wood framing and sheathing used in exterior walls are installed at least 8 inches above exposed earth (including finished grade), unless approved pressure treated or naturally durable wood species are used, **Figures 11** and **12**.

Beams and Girders in Masonry Walls

Openings or cavities in masonry walls to support the ends of beams, girders, or floor joists are of sufficient size to provide a minimum of ½-inch clearance at the top, sides and ends of such members, unless pressure preservative treated or naturally durable wood species are used, **Figure 12**.

Wood Supports Embedded in Ground

Wood supports embedded in the ground to support permanent structures shall be treated with approved pressure preservative treatments. Wood posts, poles and columns which support permanent structures and which

¹ Approved, as used in this text, means approved by the authority having jurisdiction.

by ground water, **Figure 5**. Masonry block walls are capped at the top with 4 inches of solid masonry or concrete. Drain tiles are installed around the entire footing perimeter of concrete foundations. These lead to a storm drain or sump with pump to a positive drain.

Wood Foundations

Permanent wood foundations are engineered systems consisting of wood framing and plywood sheathing that have been pressure treated with heavy concentrations of preservative to assure freedom from decay and insect attack. The system is used with both basement and crawl space foundations, **Figures 6a** and **6b**.

Permanent wood foundations are particularly suitable for cold weather construction where the entire foundation system can be prefabricated. The footing and basement area consists of a layer of gravel or crushed stone of 4-inch minimum thickness. Treated wood footing plates of adequate thickness and width are placed on the stone base at the wall perimeter. These support foundation stud walls of treated lumber framing and plywood sheathing which have been designed to support vertical and lateral loads. Exterior plywood joints are caulked and basement foundation walls are covered with 6-mil polyethylene film to direct ground water to the gravel base. Basement floors are concrete slab or wood flooring laid on treated wood joists on sleepers. A 6-mil polyethylene film is placed over the gravel base beneath the slab or wood floor.

Drain tiles are not required with permanent wood foundations. Ground water at the wall perimeter drains through the gravel footing and the gravel slab base to a sump which leads to a daylight outlet or is pumped to a storm drain, **Figure 7**. Such basements have a superior record for maintaining dry interior conditions. Additional information on Permanent Wood Foundations is available from AF&PA and the Southern Pine Council (**Appendix, Items 6** and **7**).

Other Foundations

Other foundation types include free standing piers, piers with curtain walls, or piers supporting grade beams. Piers and their footings must be of adequate size to carry the weight of the house, contents and occupants. Pier spacing will depend upon arrangement of floor framing and location of bearing walls and partitions. Spacing in the range of 8 to 12 feet is common practice, **Figure 8**.

PROTECTION AGAINST TERMITES AND DECAY

Good construction practice prevents conditions that could lead to decay or termite attack. Details for termite and decay prevention are found in *Design of Wood Struc-*

tures for Permanence-Wood Construction Data No. 6 (Appendix, Item 8). The following practices are basic:

All roots and scraps of lumber are removed from the immediate vicinity of the house before backfilling.

Loose backfill is carefully tamped to reduce settlement around the foundation perimeter. Grading at the foundation and over the building site is sloped to provide drainage away from the structure.

Unexcavated Spaces

Exposed ground in crawl spaces and under porches or decks is covered with 6-mil polyethylene film. Minimum clearance between the ground and the bottom edge of beams or girders is at least twelve inches. Clearance between the bottom of wood joists or a structural plank floor and the ground is a minimum of 18 inches, **Figure 9**. Where it is not possible to maintain these clearances, approved¹ pressure treated or naturally durable wood species are used.

Columns and Posts

Posts or columns in basements and cellars, or exposed to the weather, are supported by concrete piers or pedestals projecting at least 1 inch above concrete floors or decks and 6 inches above exposed earth. Wood posts and columns are separated from concrete piers by an impervious moisture barrier, except when approved pressure treated or naturally durable wood species are used, **Figures 9** and **10**.

Wood posts or columns which are closer than 8 inches to exposed ground in crawl spaces or supporting porches or decks are of approved pressure treated or naturally durable wood species.

Exterior walls

Wood framing and sheathing used in exterior walls are installed at least 8 inches above exposed earth (including finished grade), unless approved pressure treated or naturally durable wood species are used, **Figures 11** and **12**.

Beams and Girders in Masonry Walls

Openings or cavities in masonry walls to support the ends of beams, girders, or floor joists are of sufficient size to provide a minimum of ½-inch clearance at the top, sides and ends of such members, unless pressure preservative treated or naturally durable wood species are used, **Figure 12**.

Wood Supports Embedded in Ground

Wood supports embedded in the ground to support permanent structures shall be treated with approved pressure preservative treatments. Wood posts, poles and columns which support permanent structures and which

¹ Approved, as used in this text, means approved by the authority having jurisdiction.

are embedded in concrete in direct contact with earth or exposed to the weather, shall be treated with approved pressure preservative treatments.

Siding

A minimum clearance of 6 inches is maintained between the finished grade and the bottom edge of all types of siding used with wood frame buildings. Such clearance permits ready inspection for termite activity and improved performance of exterior paint and stain finishes.

Crawl Space Ventilation

Crawl spaces are vented by openings in foundation walls. The number and size of such vent openings are determined to provide a minimum total vent area equal to 1/150 of the crawl space ground area. For example, a 1500 sq. ft. ground area would require a total of 10 sq. ft. of vented opening, or 10 vents, each 1 square foot in net opening size. Corrosion resistant mesh with ¼-inch maximum openings is recommended.

A 6-mil plastic film ground cover in the crawl space reduces the required amount of ventilation to 10 percent of the preceding recommendation. With ground cover protection, vents may have operable louvers. Vent openings should be placed to provide cross ventilation and occur within 3 feet of corners.

Termite Control

After removal of all scrap wood from the building perimeter, treatment of the soil around the foundation with an approved termiticide is the most effective protection against subterranean termites. Properly installed termite shields also provide protection where the interiors of foundation walls are not easily inspected, [Figure 13](#).

Additional Requirements

In geographical areas where experience has demonstrated a need for more protective measures, the requirements of the preceding paragraphs may be modified to the extent required by local conditions.

FLOOR FRAMING

Floor framing consists of a system of sills, girders, joists or floor trusses and sub-flooring that provides support for floor loads and gives lateral support to exterior walls.

Sills on Foundation Walls

Sills resting on continuous masonry foundation walls are generally of nominal 2x4 or 2x6 lumber. They are anchored to masonry walls with ½-inch bolts at

approximately 6-foot intervals. Bolts are embedded at least 6 inches in poured concrete walls and at least 15 inches in masonry block walls, [Figure 14](#). Metal anchor straps, embedded in foundation walls at sufficient intervals to permit adequate nail fastening to sills, may also be used.

Sills on Piers

Sills supported by free-standing piers must be of adequate size to carry all imposed loads between piers. They may be of solid wood or of built-up construction such as described for beams and girders. Sills are anchored to piers with ½-inch bolts embedded at least 6 inches in poured concrete and at least 15 inches in masonry block, [Figure 8](#).

Beams and Girders

Beams and girders are of solid timber or built-up construction in which multiple pieces of nominal 2-inch thick lumber are nailed together with the wide faces vertical. Such pieces are nailed with two rows of 20d nails—one row near the top edge and the other near the bottom edge. Nails in each row are spaced 32 inches apart. End joints of the nailed lumber should occur over the supporting column or pier. End joints in adjacent pieces should be at least 16 inches apart, [Figure 15](#). Glued-laminated members are also used. Beams and girders that are not continuous are tied together across supports. Bearing of at least 4 inches is required at supports.

Selection and Placing of Joists

Span Tables for Joists and Rafters ([Appendix, Item 4](#)) published by the American Forest & Paper Association, provides maximum allowable spans for the different species and grades of lumber depending upon floor and roof design loads and spacing of the members.

Joist end-bearing should not be less than 1½ inches on wood or metal and 3 inches on masonry. Joists are usually attached to sills by two toe-nails, or by metal framing anchors, [Figures 8, 11 and 16](#). Joists should be placed so the top edge provides an even plane for the sub-floor and finished floor. It is preferable to frame joists into the sides of girders to reduce the cumulative effect of seasoning shrinkage, [Figures 17, 18, 19 and 20](#).

Bridging

Adequately nailed subflooring will maintain the upper edges of floor joists in proper alignment. Nailing the ends of joists to band joists or headers, [Figures 11 and 24](#), provides additional joist support that, under normal conditions, eliminates the need for intermediate bridging. Where the nominal depth-to-thickness ratio of joists exceeds 6, or where builders have encountered problems with twisting of joists in service, intermediate joist bridging

ing is installed at 8-foot intervals. Bridging may also be accomplished with cross braces of nominal 1x4-inch lumber or solid 2-inch lumber, **Figures 21** and **22**.

Framing of Floor Openings

Headers, trimmers and tail joists form the framing for floor openings. Trimmers and headers are doubled when the header span exceeds 4 feet. Headers more than 6 feet in length are supported at the ends by joist hangers or framing anchors unless they are bearing on a partition, beam or wall. Tail joists which exceed 12 feet in length are supported on framing anchors or on ledger strips not less than nominal 2x2 inches, **Figures 23, 24** and **25**.

Notching and Boring of Joists

Notches or holes in joists for plumbing or wiring shall not be cut in the middle one-third of the joist span. Notches in the outer-third sections of the span may be no greater than one-sixth the joist depth. Where notches are made at the joist ends for ledger support, they may be no greater than one-fourth the joist depth. Holes in the outer-third joist sections are limited in diameter to one-third the joist depth and are cut with the edge of the hole no closer than 2 inches to the top or bottom edges, **Figure 26**.

Support of Partitions

Bearing partitions are normally placed over girders or walls which support the floor system. Where floor framing is adequate to support the added load, bearing partitions may be offset from supporting members by no more than the joist depth, unless floor joists are designed to carry the increased load, **Figures 27** and **28**.

Where non-bearing partitions run parallel to floor joists, the joist under the partition is doubled to support increased loads which frequently occur adjacent to the partition, **Figures 29** and **30**.

Overhang of Floors

Where second-floor joists project over the first story wall at right angles, they are cantilevered to support the second story wall, **Figure 35**. Where the overhanging wall is parallel to the second floor joists, a double joist supports lookout joists which extend at right angles over the first story wall, **Figure 36**. The double joist is located inside the supporting wall at a distance equal to twice the overhang. Lookout joists are framed into the double joist by framing anchors or a ledger strip nailed at the upper edge.

FIRESTOPPING

All concealed spaces in wood framing are firestopped with wood blocking or other approved materials. Blocking must be accurately fitted to fill the opening and to prevent drafts between spaces, **Figures 2, 16, 27, 28, 31,** and **32**.

Openings around vents, pipes, ducts, chimneys, fireplaces and similar fixtures which would allow passage of fire are filled with non-combustible material, **Figure 37**.

Other firestopping requires 2-inch lumber or two thicknesses of 1-inch lumber with staggered joints, or one thickness of ¾-inch plywood with joints backed by 1-inch lumber or ¾-inch plywood.

Sills and plates normally provide adequate firestopping in walls and partitions. However, stopping is required at all intersections between vertical and horizontal spaces such as occur at soffits, dropped ceilings and coved ceilings, **Figure 38**.

Furred spaces on masonry walls are firestopped at each floor level and at the ceiling level by wood blocking or by non-combustible material of sufficient thickness to fill the space, **Figure 39**.

DRAFTSTOPPING

In single family residences, draftstopping is required parallel to main framing members in floor/ceiling assemblies separating usable spaces into two or more approximately equal areas with no area greater than 500 square feet. Materials for draftstopping may be 3/8-inch plywood or ½-inch gypsum board, **Figure 40**.

EXTERIOR WALL FRAMING

Exterior wall framing must be of adequate size and strength to support floor and roof loads. Walls must also resist lateral wind loads and, in some locations, earthquake forces. Top plates are doubled and lapped at corners and at bearing partition intersections to tie the building into a strong structural unit. A single top plate may be used where roof rafters or trusses bear directly above wall studs. In such cases adequate corner ties are required, particularly where non-structural sheathing is used.

Stud Size and Spacing

Studs in exterior walls of one and two-story buildings are at least nominal 2x4 inches with the 4-inch dimension forming the basic wall thickness. Stud spacing is normally 16 inches in exterior walls, although 24-inch spacing of 2x4 studs is acceptable in one-story buildings if wall sheathing or siding is of adequate thickness to bridge

across studs. In three-story buildings studs in the bottom story are at least nominal 3x4 or 2x6 inches and may not exceed 16-inch spacing.

Studs are arranged in multiples at corners and partition intersections to provide for rigid attachment of sheathing, siding and interior wall finish materials. Nailing strips or metal clips may be used to back up interior finish at corners, **Figures 41** and **42**.

Exterior Wall Openings

A header of adequate size is required at window and door openings to carry vertical loads across the opening. Headers may be supported by doubled studs or, where the span does not exceed 3 feet, framing anchors may be used with single supporting studs, **Figures 43** and **44**. Where the opening width exceeds 6 feet, triple studs are used with each end of the header bearing on two studs.

Gable End Walls

Studs at gable ends bear on the top plate and are notched and nailed to the end rafter, **Figure 46**.

Wall Sheathing

The high resistance of wood frame construction to hurricane, earthquake and other forces of nature is provided when wood sheathing is adequately nailed to the outside edges of exterior wall studs, plates and headers. Wall sheathing includes plywood, particleboard and other structural panels such as wafer-board, oriented-strand board, structural insulation board and one-inch board lumber. Such sheathing is applied in strict accordance with manufacturer's nailing requirements to provide a rigid, yet resilient, wood frame system. Some structural panels function as both sheathing and siding.

Where the building exterior is to be stuccoed, where plastic foam sheathing is used, or where bevel or other lap siding is applied directly to the studs, exterior walls must be braced at the corners with 1x4 lumber which has been "let-in" to the outside surfaces of studs, plates and headers at an angle of 45 degrees, **Figures 1** and **2**. Metal strap braces adequately nailed may be used. Plywood or other structural panels applied vertically at each corner also serve as adequate corner bracing where non-structural sheathing is otherwise used.

Building or Sheathing Paper

Walls are protected from wind and water infiltration by covering the wall sheathing with a layer of Type 15 asphalt saturated felt paper or with other suitable water repellent paper or plastic films. Such coverings must permit passage of any moisture vapor which enters the wall system from the interior and have a vapor permeability

rating of five or greater. Six-inch wide strips of sheathing paper are applied around all wall openings and behind all exterior trim, **Figures 49** and **50**. Sheathing paper is applied from the bottom of the wall, lapping horizontal joints 4 inches and vertical joints 6 inches.

INTERIOR PARTITION FRAMING

There are two types of interior partitions: bearing partitions which support floors, ceilings or roofs; and non-bearing partitions which carry only the weight of the materials in the partition, including attachments in the finished building.

Bearing Partitions

Studs in bearing partitions should be at least nominal 2x4 inches, with the wide surface of the stud at right angles to top and bottom plates or headers. Plates are lapped or tied into exterior walls at intersection points.

Single top plates are permitted where joists or rafters are supported directly over bearing wall studs. Studs supporting floors are spaced a maximum of 16 inches on center. Studs supporting ceilings may be spaced 24 inches on center. Headers in bearing walls are used to carry loads over openings, as required for exterior walls.

Non-Bearing Partitions

Studs in non-bearing partitions are nominal 2x3 or 2x4 inches and may be installed with the wide face perpendicular or parallel to the wall surface. Single top plates are used. Stud spacing is 16- or 24-inches on center as required by the wall covering.

FRAMING AROUND CHIMNEYS AND FIREPLACES

Framing

Wood framing must be adequately separated from fireplace and chimney masonry, **Figures 47a** and **47b**. All headers, beams, joists and studs must be kept at least two inches from the outside face of chimney and fireplace masonry. Prefabricated metal fireplace and chimney assemblies are to be installed in accordance with the manufacturer's recommendations and must be approved by the code authority.

Trim

Wood mantles and similar trim are separated from fireplace openings by at least six inches, **Figures 48a** and **48b**. Where combustible material is within 12 inches of the fireplace opening, the projection shall not exceed ½ inch for each 1-inch distance from such opening.

ROOF AND CEILING FRAMING

Roof construction must be of adequate strength to withstand anticipated snow and wind loads. Framing members must be securely fastened to each other, to sheathing and to exterior walls to enable the roof system to serve as a structural unit, **Figures 51** through **59**.

Ceiling Joist and Rafter Framing

Maximum allowable spans for ceiling joists and rafters for various lumber grades and species are provided in *Span Tables for Joists and Rafters*, (**Appendix, Item 4**).

Ceiling joists must be securely nailed to exterior wall plates, to the ends of rafters and where the joists join over interior partitions. This provides a structural tie across the building to withstand outward forces exerted by the rafters, **Figure 51**. Ceiling joists at right angles to rafters are to be avoided, **Figure 52**.

The ridge member is of 1- or 2-inch thick lumber and is 2 inches deeper than the depth of the rafters to permit full bearing at the angled rafter ends. Rafters are placed directly opposite each other across the ridge and are notched at the lower end to fit the exterior wall top plate, **Figures 53** and **57**. Rafters are secured to the wall plate by toe-nailing or use of special metal plate fastenings.

Collar Beams (collar ties)

Collar beams of nominal 1x6 or 2x4 lumber are installed in the upper one-third of the attic space to every third pair of rafters to secure the ridge framing.

Valley and Hip Rafter Framing

Valley rafters at the intersection of two roof areas are doubled in thickness and two inches deeper than adjoining rafters, **Figure 55**.

Hip rafters are of single thickness but are two inches deeper than common rafters to permit full bearing of jack rafters, **Figure 56**.

Where ridges occur at different elevations, provision must be made for vertical support of the interior end of the lower ridge board.

Roof Trusses

Roof framing may be fabricated as light trusses and installed as complete units. Such framing is designed according to accepted engineering practice. The truss members are joined together by fasteners such as nails, nails and glue, bolts, metal plates or other framing devices.

Use of roof trusses eliminates the need for interior bearing partitions and frequently results in more rapid in-

stallation of roof and ceiling framing. Roof trusses are generally spaced 24 inches on center.

Where roof trusses are used, gable ends are usually framed in the conventional manner using a common rafter to which gable end studs are nailed. Eave overhangs are framed by extending the top chords of the trusses beyond the wall.

Where hip and valley construction is required, modified trusses or conventional framing are used to meet the condition.

Ceiling-Floor-Partition Separation

In some localities truss uplift may be a problem. This problem is characterized by the separation of the floor or ceiling from an interior partition.

A widely used technique to minimize truss uplift separation is to allow the gypsum board ceiling to “float” or rest on the partition and remain unattached to the truss on either side of the partition. In cases where trusses are perpendicular to partitions, the gypsum board ceiling remains unattached at least 18 inches from the ceiling/ wall intersection, **Figure 68**. Additional solutions to this separation are found in two reports referenced in **Appendix, Items 12** and **13**.

Flat Roofs

Flat roofs should be avoided if possible because they are difficult to ventilate and insulate adequately and present weather proofing problems. Where flat roofs are used, rafters or roof joists serve as ceiling joists for the space below, **Figure 54**. Maximum allowable spans for ceiling joists and rafters are contained in *Span Tables for Joists and Rafters*, (**Appendix, Item 4**). Flat roof joists are securely nailed to exterior wall plates and to each other where they join over interior partitions.

Roof Sheathing

Wood structural panels or 1-inch board lumber provides a solid base for roof coverings. Structural panels are manufactured in various thicknesses and are usually 4'x8' in surface dimension. Recommended spans, spacing between panel edges and thickness are stamped on the panel face. Structural panels are installed with the long dimension perpendicular to rafters and with the panel continuous over two or more spans.

Spaced Sheathing

Where wood shingles or shakes are to be applied as the finished roof, solid sheathing is used or nominal 1x4 lumber is nailed perpendicular to rafters and trusses with each board spaced a distance from the next board equal to the weather exposure of the shingles or shakes. (5½ inches

is common exposure for shingles. Shakes may be exposed 7 to 13 inches depending on their length.) Because shakes are not smooth surfaced, an 18-inch wide underlay of asphalt felt is used between each course. Where wind driven snow is encountered, solid sheathing and Type 15 asphalt felt are used under wood shakes.

Ventilation of Attic Spaces

Ventilation of all attic spaces is required to eliminate moisture condensation on roof framing in cold weather and to permit heat to escape in warm weather, **Figure 61**.

For gable roofs, a screened, louvered opening is used which provides a net open area of 1/150 of the area of the ceiling below. Where a 3/4-inch wide screened slot is also provided in the eave soffits, or where a vapor retarder having one perm or less permeability is installed on the warm side of the ceiling, the total ventilating area may be reduced to 1/300 of the ceiling area.

With hip roof construction, a 3/4-inch wide screened slot in the eave soffits, and ventilator at the ridge to provide 1/450 inlet and 1/900 outlet fractions of the ceiling area below, assures adequate ventilation.

For flat roofs, blocking, bridging and insulation are arranged to prevent obstruction of air flow. Such roofs are ventilated at eave soffits to provide net open area equal to 1/250 of the area of the ceiling below. A vapor retarder of one perm or less permeability is applied under the ceiling finish below flat roofs.

INSULATION AND VAPOR RETARDERS

Insulation

Adequate insulation in stud spaces of exterior walls, between floor and ceiling joists or rafters and on the inside of masonry foundations between grade line and first floor, make wood frame construction efficient to heat and cool. It also increases occupant comfort and absorbs outside noises. Roll or batt-type insulation is installed full thickness in exterior walls or between rafters. Roll or loose fill insulation is used in attics between ceiling joists. Rigid foam plastic is bonded to the inside of foundation walls with construction adhesive.

Vapor Retarders

Vapor retardant film prevents moisture vapor from moving through the insulated wall and condensing on the back side of sheathing and siding. Such condensation greatly reduces the effectiveness of insulation and causes failures of exterior paints and finishes.

Wall insulation batts usually have vapor retardant paper covers facing the room interior. However, the most common method of installing wall insulation batts cre-

ates gaps along each stud, which make this type of vapor protection of little value. Proper vapor protection requires a 4-mil (.004") minimum thickness of polyethylene film stapled to wall studs immediately beneath the dry wall or other interior finish. The film is carefully fitted around window and door openings and behind electric outlets.

Crawl spaces and basement concrete slabs are also sources of moisture vapor, which reduce the effectiveness of insulation and create expansion problems with hardwood flooring. A 6-mil (.006") polyethylene film placed over the ground in crawl spaces and over the gravel before the basement slab is poured is the most effective method of controlling moisture vapor from the ground.

Some plastic foam sheathings and foil-faced sheathing may act as vapor retarders on the *outside* of exterior walls. Where such sheathing panels are used, it is essential that a vapor retardant polyethylene film be placed on the inside wall surface, beneath the interior wall finish.

EXTERIOR SIDING AND COVERINGS

Many types of wood, hardboard, shingle, structural panel, metal and masonry veneer sidings are used over wood framing. Such materials are separated from the final, finished grade by a minimum of 6 inches, **Figure 49**.

Wood Siding

A variety of wood and hardboard siding patterns are available. Bevel, shiplap and drop types are generally used horizontally. Board-and-batten, board-on-board and tongued and grooved boards are applied vertically, **Figure 63**. Surfaces are smooth, rough sawn or overlaid with paper or plastic film. They may be natural or factory pre-primed or pre-finished.

Siding and exterior trim are applied over a layer of Type 15 asphalt felt or other water repellent sheathing cover with corrosion-resistant nails. Hot dipped galvanized steel, stainless steel or aluminum nails may be used. Nail length varies with the thickness of siding and sheathing. For smooth shank siding nails, required length is determined by adding to the combined siding and sheathing thickness an additional 1½ inches for penetration into solid wood.

Where foam sheathing or insulation board sheathing are used, "solid wood" means 1½-inch nail penetration into the stud. However, where plywood, waferboard or oriented strand board sheathing are used, the thickness of these panels becomes a part of the 1½-inch solid wood nail penetration.

Ring-shank or spiral-shank siding nails have additional holding power. A reduction of 1/8 to 1/4 inch in required nail penetration into solid wood is permitted for these fas-

teners. Additional requirements apply to use of rigid foam plastic sheathing, and are published by AF&PA (**Appendix, Item 9**).

Bevel siding and square edged boards applied horizontally are nailed with a single nail at each stud. The minimum lap is 1 inch, with the nail driven approximately 1½ inches above the lap, **Figure 63(a)**.

Drop and shiplap type sidings, which lay flush against the sheathing paper, are nailed at each stud with a single nail approximately 1½ inches above the drip edge. Where siding width is 8 inches or more or where sheathing is omitted, two nails are used, **Figure 63(b)**.

Corner treatment is governed by the house design. Corner boards, mitered corners, metal corner covers or alternately lapped corners are used, **Figure 64**.

Board siding, both square edge and tongue and grooved, is applied vertically, **Figures 63(c) and 63(d)**. Where wood, plywood or structural panel sheathing of ½-inch minimum thickness is used, nails are spaced 16 inches vertically. For other types of sheathing, horizontal nominal 1x4-inch furring strips are applied at 24-inch intervals as a nail base for vertical siding application. Where stud spacing exceeds 16 inches, inter-stud blocking with 2-inch lumber between studs is required.

Protection of Siding

Ends of wood siding at corners, butt joints and at joints with window and door trim are protected by an application of clear water repellent preservative. Dipping at the time of siding application or subsequent brush or spray treatment before caulking and painting are effective. Where wood siding is to be left to weather unfinished, a liberal coat of clear water repellent preservative is applied to the entire exterior siding surface.

Wood Shingles and Shakes

Shingles and shakes used as exterior wall covering are applied with the weather exposures in **Table II**.

Shingles and shakes are nailed with corrosion resistant nails of sufficient length to penetrate wood sheathing. Two nails are used for widths up to 8 inches. For wider shingles and shakes, three nails are used.

With single course applications nails are driven one inch above the butt line of the succeeding course. In double coursing the under course is attached to wood sheathing with three nails or staples. The outer course is applied with small-headed nails driven approximately 1 inch above the butts and ¾ inch from the edges.

Where other than wood, plywood, waferboard or oriented-strand board sheathing is used, a nail base of 1x3-inch wood furring strips is applied horizontally at in-

tervals equal to the weather exposure of the shingles or shakes, **Figure 50**.

Masonry Veneer

Masonry veneer applied to wood frame construction is supported on the masonry foundation wall. Where permanent wood foundations are used, masonry veneer is supported on the preservative treated wood footing plate or on a preservative treated wood knee wall attached to the wood foundation with corrosion resistant metal ties. Ties are spaced horizontally 24 inches on center, with each tie supporting no more than two square feet of wall area. Ties are fastened through sheathing directly to foundation studs, **Figure 65**.

In masonry veneer applications to permanent wood foundations, a 1-inch space is left between sheathing and masonry. Base flashing extends from the outside face of the masonry wall over the foundation and up the sheathing a minimum distance of 12 inches. Weep holes are provided by leaving open vertical joints at 4-foot intervals in the bottom course of masonry veneer.

FLOORING

Flooring consists of the subfloor, underlayment and finish floor. Depending upon the type of finish floor or subfloor used, underlayment may not be required. Where 25/32-inch tongue and grooved wood strip flooring is used, it may be laid directly over the subfloor, **Figure 66**. Where lesser thicknesses of wood strip flooring are used, the thickness and grade of subflooring must be adequate to support end joints at full design load, unless they occur over joists.

Underlayment is normally applied over the sub-floor where resilient tile, sheet vinyl or carpet is used as the finish floor surface.

Sub-flooring

The sub-floor usually consists of plywood, particle-board or other wood structural panels, or board lumber. Lumber sub-flooring is typically laid diagonally to permit wood strip finish flooring to be laid either parallel with or at right angles to, the floor joists. End-joints in sub-flooring are cut to occur over joists.

Wood structural panels are typically installed with the long dimension at right angles to the joists and with the panel continuous over two or more spans. Spacing between panels should be approximately 1/8 inch.

Underlayment

Underlayment panels are applied over sub-flooring to provide a smooth surface for application of carpeting and other resilient floor coverings. Plywood underlayment

requirements are covered by U.S. Product Standard PS 1-95, which is published by APA-The Engineered Wood Association (**Appendix, Item 10**). Hardboard underlayment requirements are set forth in ANSI/AHA A135.4 (**Appendix, Item 11**) published by the American Hardboard Association. Application of finish floor coverings is generally by specialists who follow the manufacturer's installation instructions for the carpet, resilient tile or vinyl products.

Wood Flooring

Hardwood and softwood strip flooring of 3/4-inch or 25/32-inch thickness provides adequate strength and stiffness for direct application over sub-flooring at right angles to joists. Where parquet (squares) are used or where strip flooring is laid parallel to joists, the grade and thickness of sub-flooring panels must be adequate to provide support between joists. An additional thickness of subflooring may be required over the rough subfloor in such applications.

Wood strip flooring is normally applied over building paper and is sanded and finished after installation. An expansion joint of at least one-half inch must be provided at the edge of flooring strips adjacent to parallel partitions and exterior walls. This joint is covered by the baseplate and toe molding.

WOOD DECKS

Wood decks are a special feature of many new houses and a useful add-on to others. Their capability for providing additional low-cost living and recreational space makes it important to consider them as part of the original house design. Use of pressure treated and naturally durable lumber has made these outdoor structures as permanent as the house itself.

Supporting joists, posts and decking lumber must be properly grade marked and identified as naturally durable or pressure preservative treated wood by quality control agencies approved by the model building codes or the dwelling codes.

Design

Deck shape and size should be consistent with the general lines of the house and should be positioned to function as part of the total structure. Orientation for sun exposure and shade is particularly important in location of the deck.

Engineering

Cantilevered and other special deck types should be properly engineered. Forty pounds per square foot is a

minimum design live load, considering the concentration of people frequently supported by decks. The applicable code will govern this requirement.

The initial header joist for the deck is attached to a band or header joist of the house with through bolts or lag screws, **Figure 67**. The level of the deck framing, including the 1½-inch decking thickness is determined so that the deck surface is at least one inch below that of the interior floor surface. If deck height is significantly different from that of the band or header joists of the house, the deck header must be securely fastened to the wall studs. Joists are attached to the header by proper toe-nailing, preferably, by metal hangers to prevent splitting. Corrosion resistant hangers and hot-dipped galvanized or stainless steel nails are required.

Post lengths are determined after deck framing has been supported on temporary 2x4 posts. For posts, pressure preservative treated for ground contact, footing holes are dug at required points. Concrete or gravel bases of 4-inch minimum thickness below the frost line are placed over compacted soil in the holes. From the concrete or gravel base required length of post to the deck level can be determined.

Footings for naturally durable wood posts extend 6 inches above grade. Pre-cast concrete piers or concrete block piers with imbedded ½-inch re-enforcing bar pins or treated wood nailers are used to secure posts against lateral movement, **Figure 67**.

Decking

The floor of the deck is normally 2x4-inch or 2x6-inch lumber. It is nailed with the end-grain showing the "bark-side-up." Where pressure preservative treated lumber or unseasoned naturally durable lumber species are used, decking pieces can be nailed in contact or spaced no farther apart than a nail diameter. Kiln dried decking can be laid with a maximum spacing of ¼-inch.

Decking nails must be good quality hot-dipped galvanized, aluminum or stainless steel. Two 16d nails are driven at slight angles to each other at each joist position, **Figure 67**. Butt joints in 2x6 decking require three nails.

Railings

Railing designs follow the style of the house. Railings must be securely anchored to the deck, preferably including an extension of the posts. Openings in the railing are limited to six inches, or as the code requires.

Finishes

Both pressure treated and naturally durable wood are resistant to decay and insects. However, a good water-repellent stain or paint finish will protect against checking

and maintain the attractiveness of the deck. Application of a clear water repellent preservative immediately upon completion of the deck is recommended for both pressure treated and naturally durable lumber.

CONCLUSION

The home is, for many families, the major investment of a lifetime. While, in a mobile society, many families will have lived in several homes, each structure should serve as a prized possession, capable of providing comfortable shelter for a succession of satisfied occupants.

Basic house construction follows simple engineering principles. In addition, the workmanship of the home, which involves carpentry and a number of other construction trades, is in many ways a truly American art-form. This publication provides essential requirements for construction, and information to assist in the design, construction and inspection of wood structures of proven durability and performance.

Table I. Nominal and Minimum-Dressed Sizes of Boards, Dimension and Timbers.^a

The thicknesses apply to all widths and all widths apply to all thicknesses. Sizes are given in inches and millimeters. Metric units are based on dressed size - see Appendix B, PS 20-99 for rounding rule.

	Thicknesses					Face Widths				
	Nom. inch	Minimum Dressed				Nom. inch	Minimum Dressed			
		Dry ^b		Green ^b			Dry ^b		Green ^b	
	inch	mm	inch	mm	inch	mm	inch	mm		
Boards					2	1-1/2	38	1-9/16	40	
					3	2-1/2	64	2-9/16	65	
					4	3-1/2	89	3-9/16	90	
					5	4-1/2	114	4-5/8	117	
		3/4	16	11/16	17	6	5-1/2	140	5-5/8	143
		1	19	25/32	20	7	6-1/2	165	6-5/8	168
		1-1/4	25	1-1/32	26	8	7-1/4	184	7-1/2	190
		1-1/2	32	1-9/32	33	9	8-1/4	210	8-1/2	216
						10	9-1/4	235	9-1/2	241
						11	10-1/4	260	10-1/2	267
						12	11-1/4	286	11-1/2	292
						14	13-1/4	337	13-1/2	343
						16	15-1/4	387	15-1/2	394
	Dimension					2	1-1/2	38	1-9/16	40
						2-1/2	2	51	2-1/16	52
			2	38	1-9/16	40	3	2-1/2	64	2-9/16
		2-1/2	51	2-1/16	52	3-1/2	3	76	3-1/16	78
		3	64	2-9/16	65	4	3-1/2	89	3-9/16	90
		3-1/2	76	3-1/16	78	4-1/2	4	102	4-1/16	103
		4	89	3-9/16	90	5	4-1/2	114	4-5/8	117
		4-1/2	102	4-1/16	103	6	5-1/2	140	5-5/8	143
						8	7-1/4	184	7-1/2	190
						10	9-1/4	235	9-1/2	241
						12	11-1/4	286	11-1/2	292
						14	13-1/4	337	13-1/2	343
					16	15-1/4	387	15-1/2	394	
Timbers	5 & thicker		½ off	13 off	5 & wider			½ off	13 off	

^aBased on Voluntary Product Standard DOC PS 20-99, American Softwood Lumber Standard. U.S. Department of Commerce. September 1999.

^bSee sections 2.7 and 2.11, PS 20-99 for the definitions of dry and green lumber.

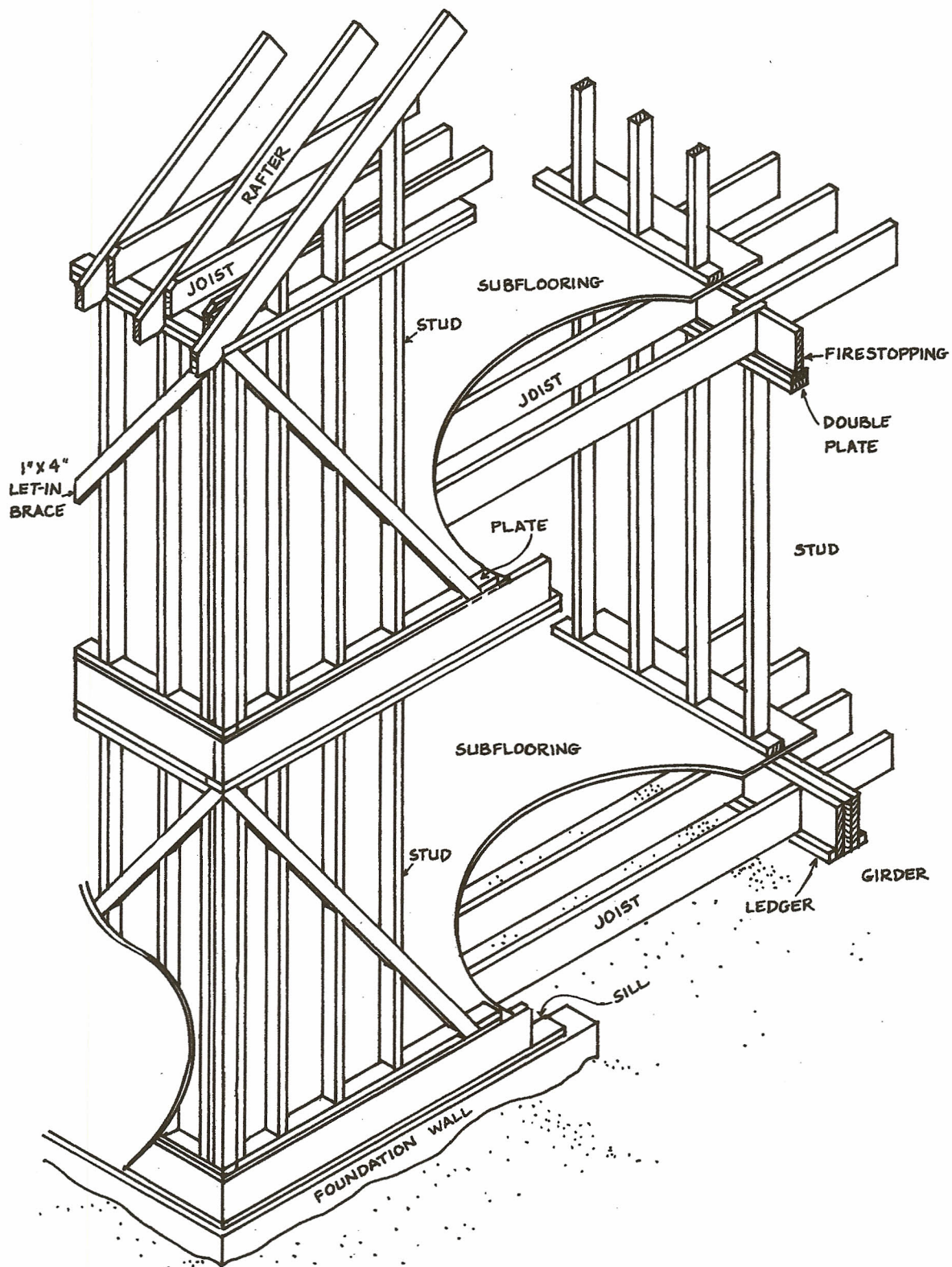
Figure 1. Platform Frame Construction

Figure 2. Balloon Frame Construction

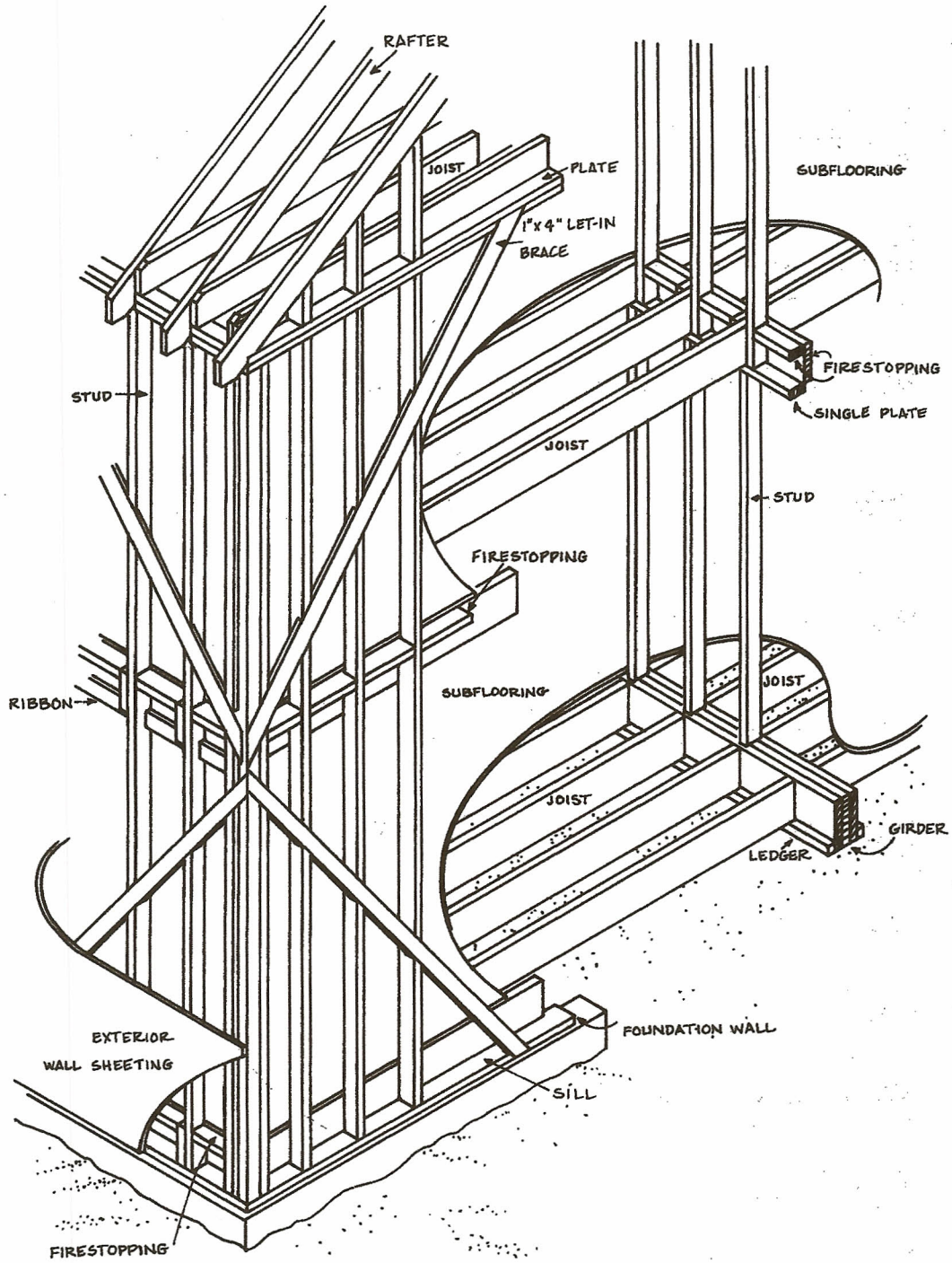


Figure 3. Methods of Loading Nails

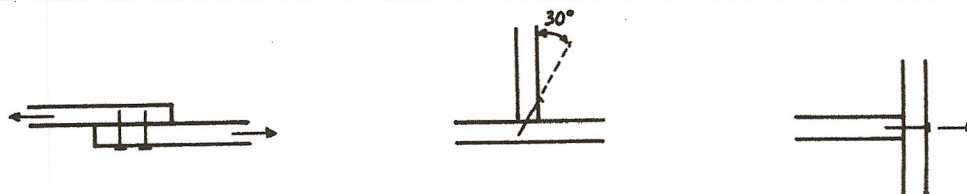
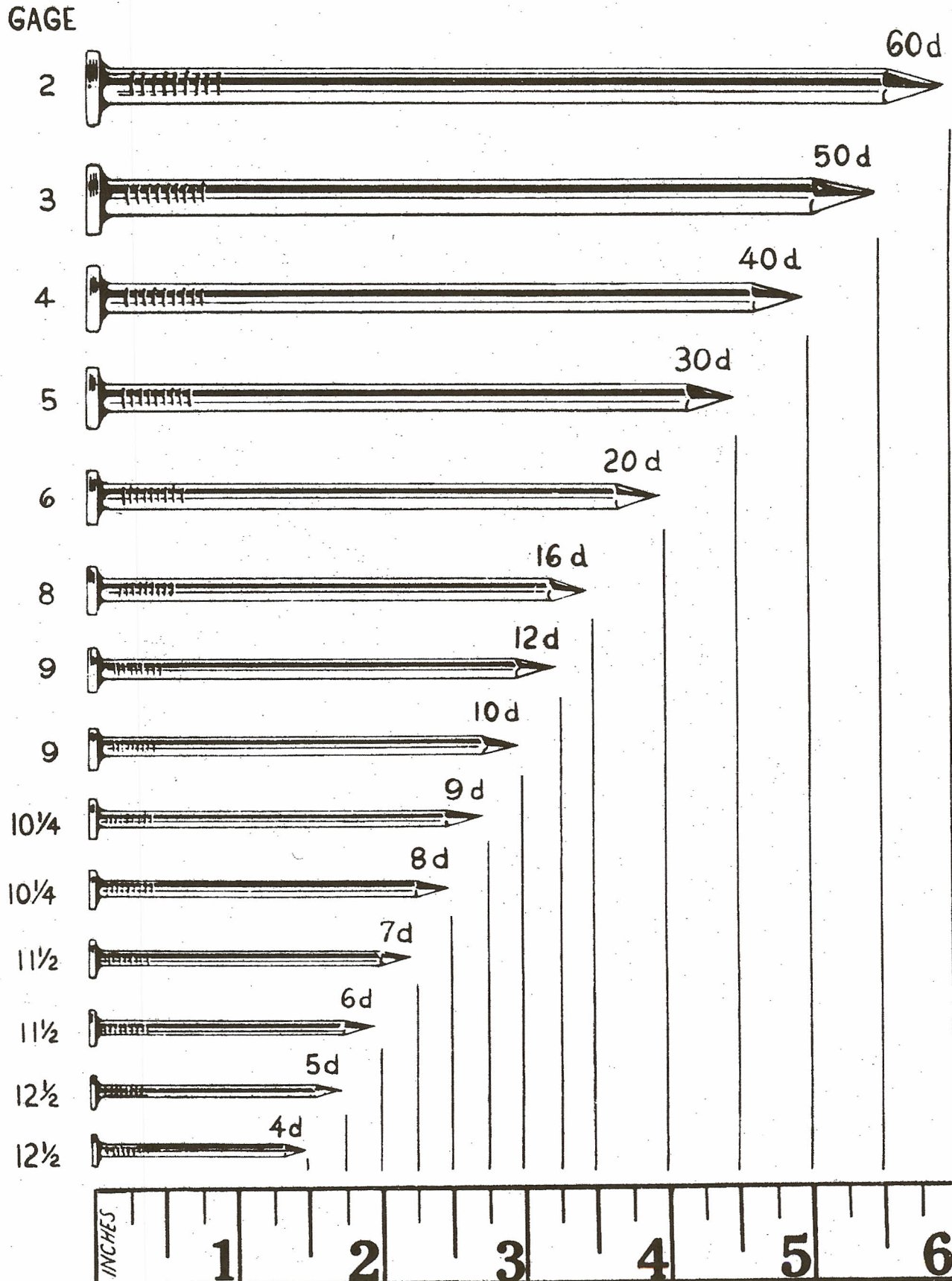


Figure 4. Sizes of Common Wire Nails



Note: Print to scale to ensure accurate measurements. Do NOT check "Fit to Page."

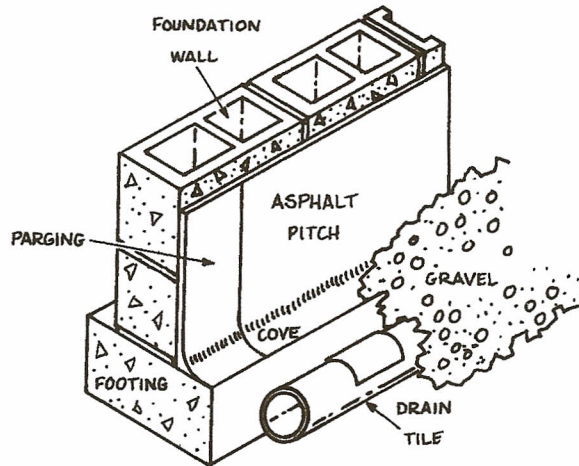
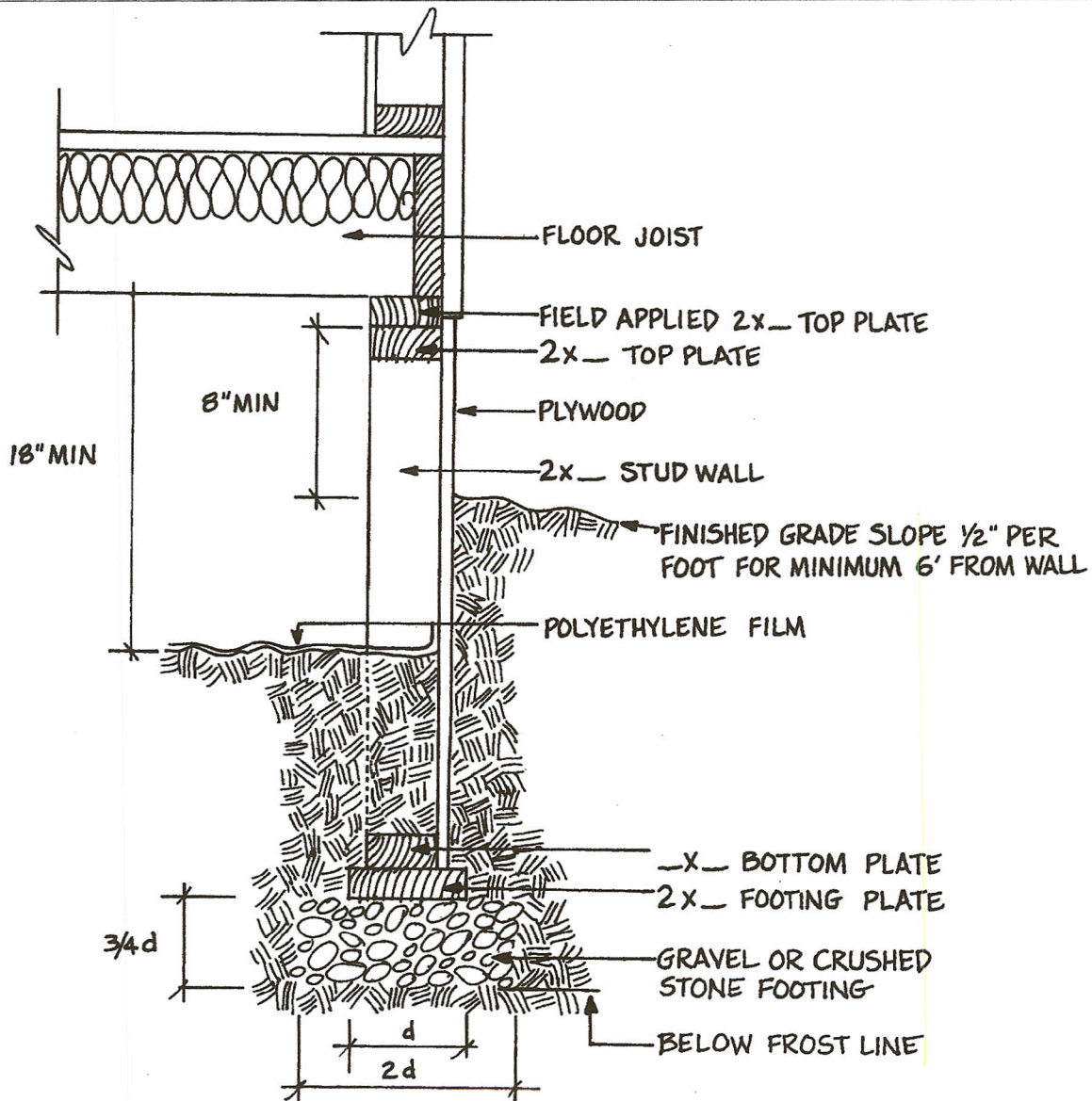
Figure 5. Masonry Foundation Wall and Footing**Figure 6a. Permanent Wood Foundation - Crawl space**

Figure 6b. Permanent Wood Foundation - Basement

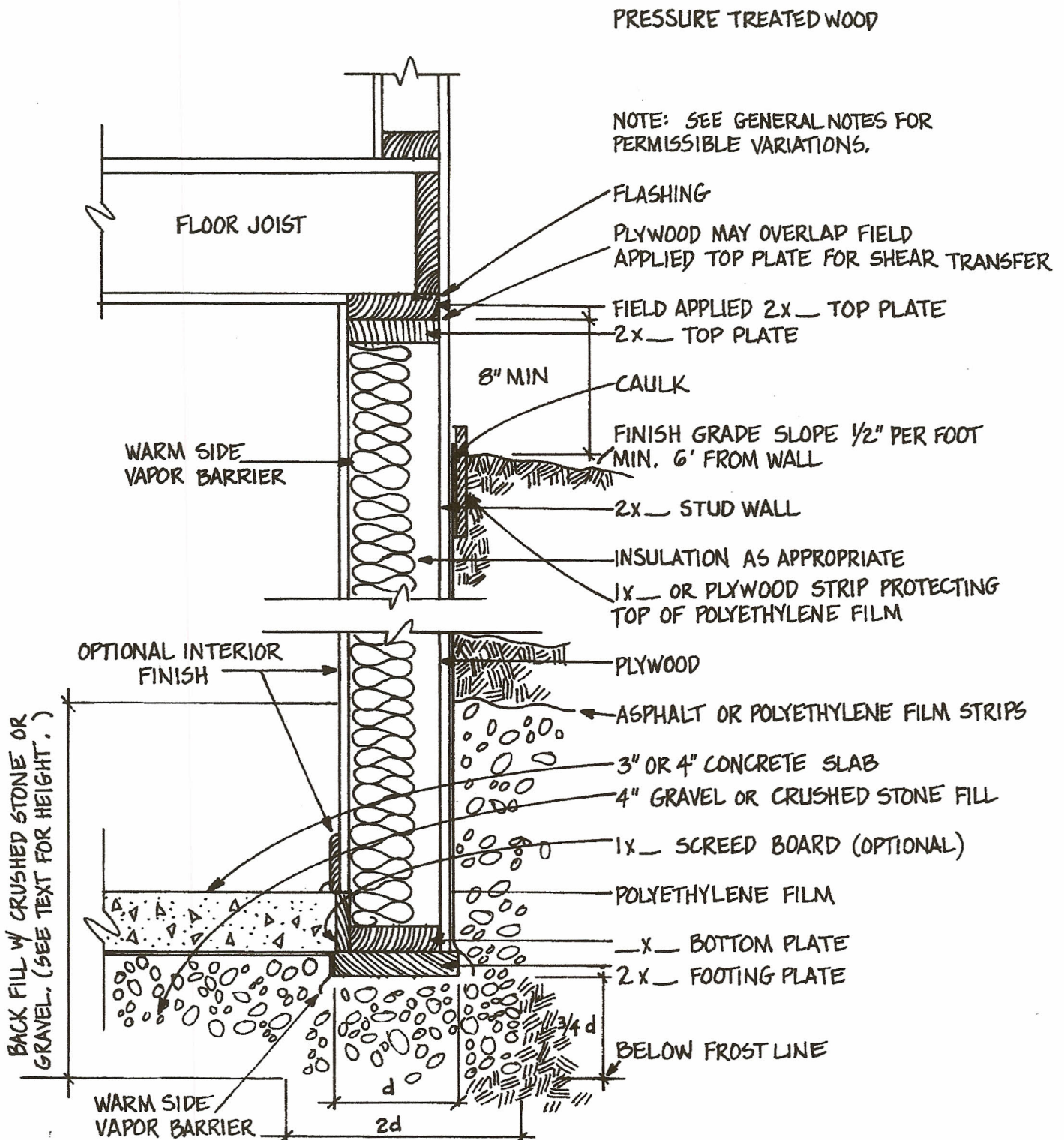
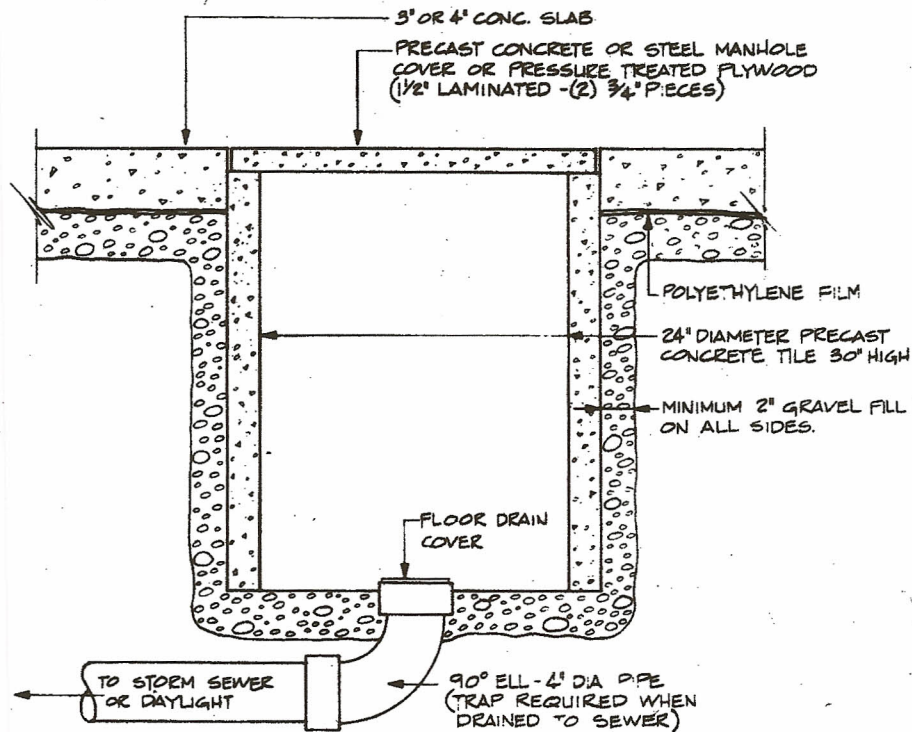
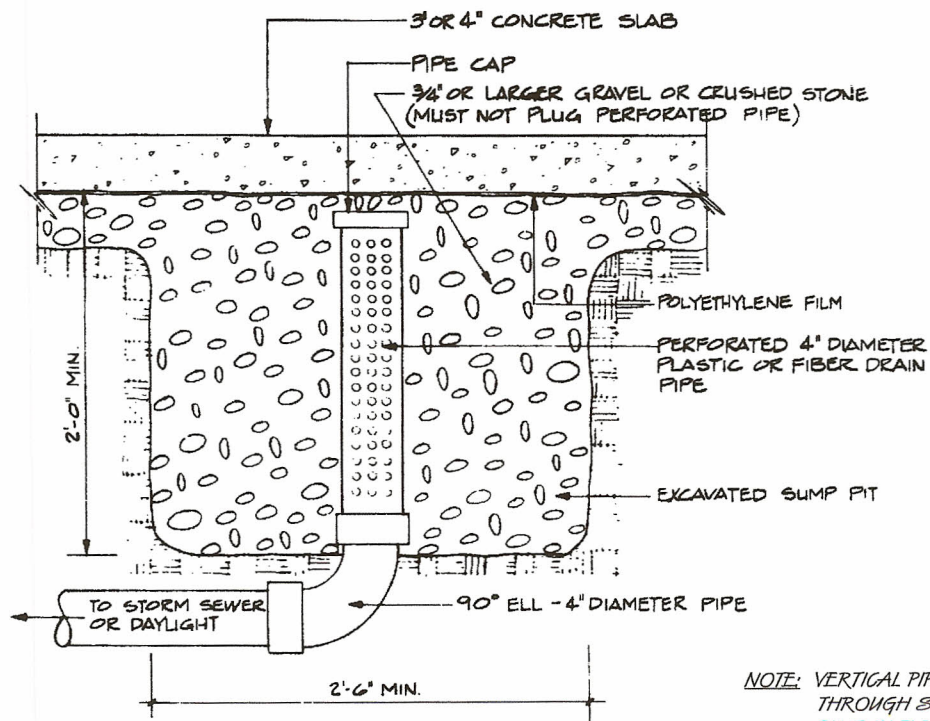


Figure 7a. Sump for Poorly Drained Soils

NOTE: 1. USE OF SUMP PUMP IS OPTIONAL
 2. 24 INCH DIAMETER OR 20 INCH SQUARE TERRAZZOTA TILE OR TREATED WOOD BOX MAY BE SUBSTITUTED FOR PRECAST CONCRETE TILE

**Figure 7b. Sump for Medium to Well Drained Soils**

NOTE: VERTICAL PIPE MAY BE EXTENDED THROUGH SLAB WITH A CLEANOUT PLUG IN FLOOR

Figure 8. Pier Foundation and Anchorage

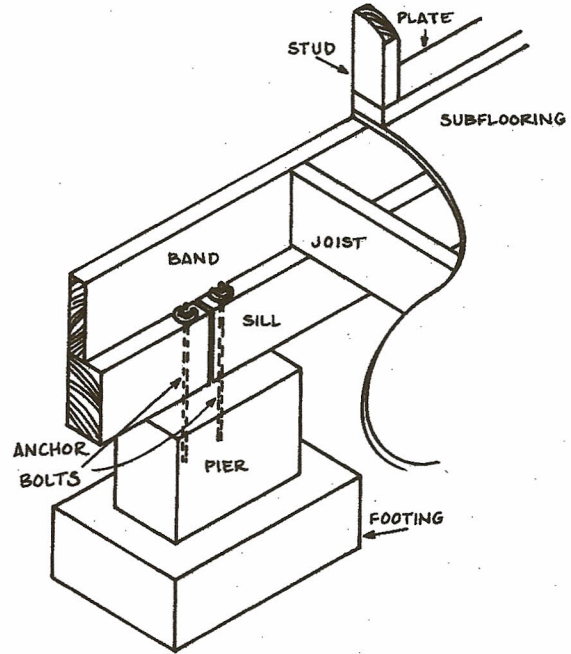


Figure 9. Clearance Between Earth and Floor Framing

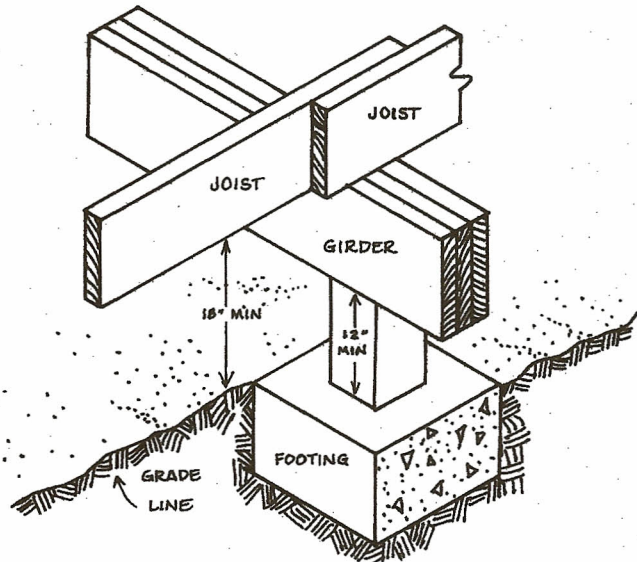


Figure 10. Support for Basement Post

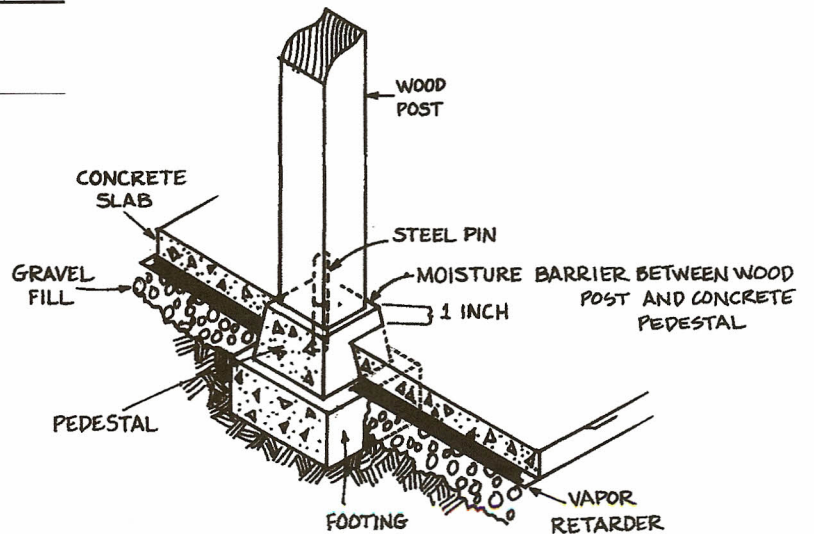


Figure 11. Floor Framing at Exterior Wall

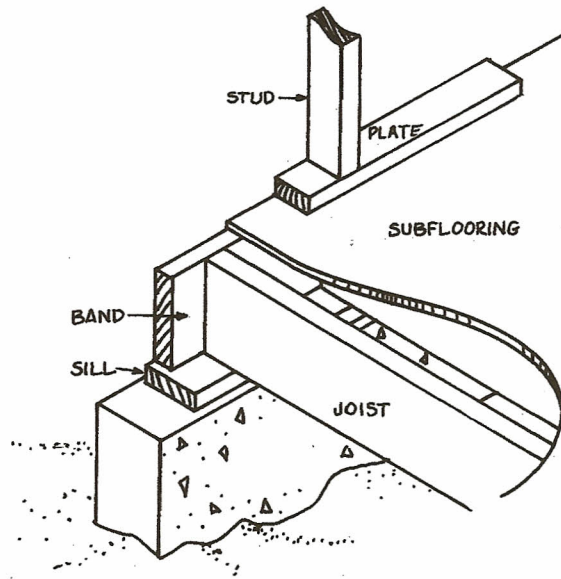


Figure 12. Girder Framing in Exterior Wall

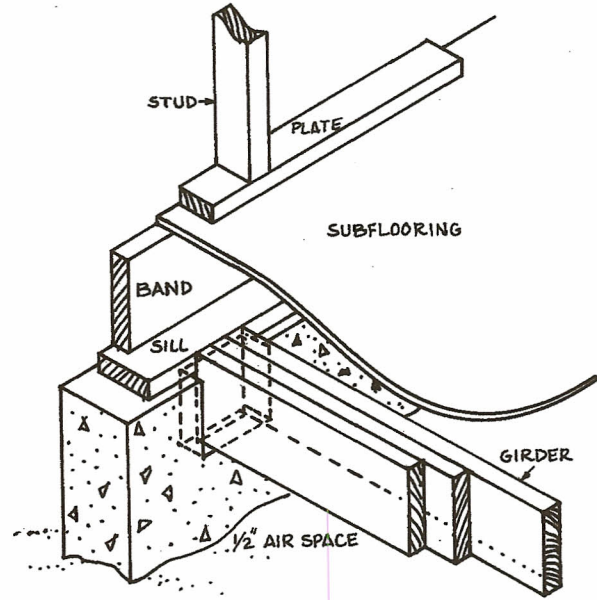


Figure 13. Termite Shields

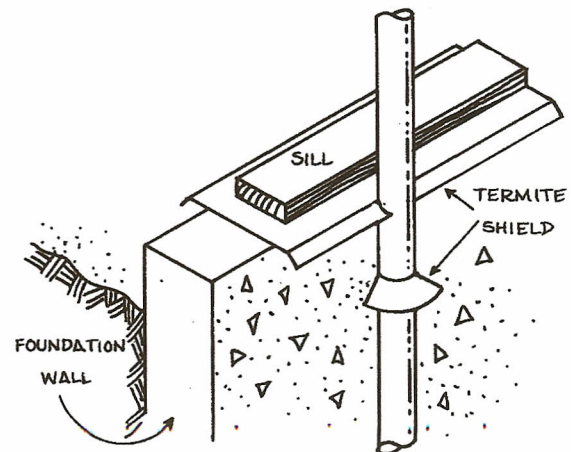


Figure 14. Anchorage of Sill to Foundation Wall

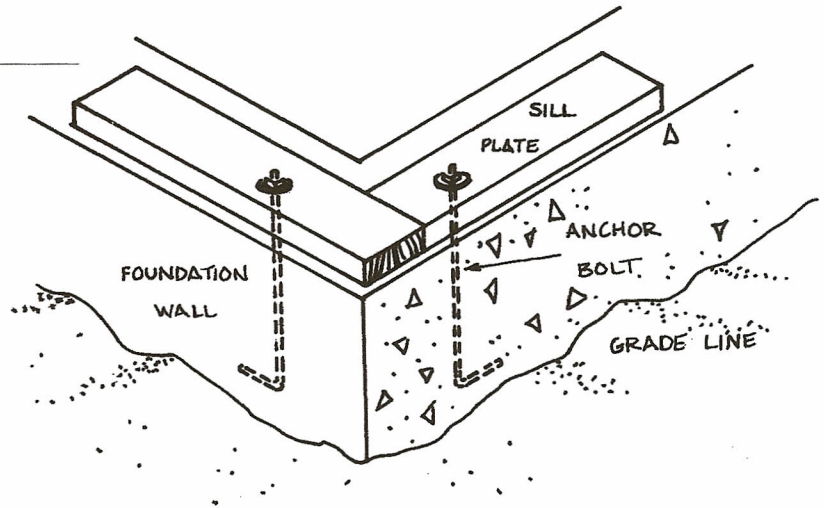


Figure 15. Nailing Built-up Beams and Girders

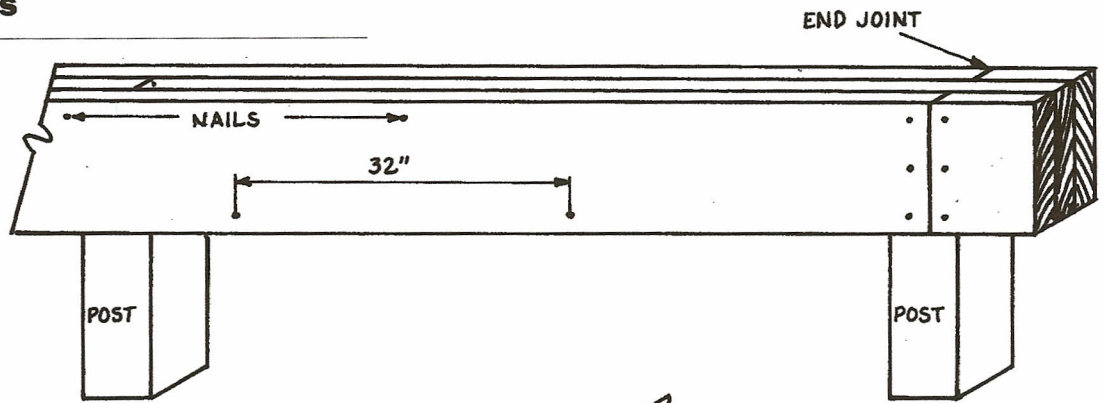


Figure 16. Joist End Bearing

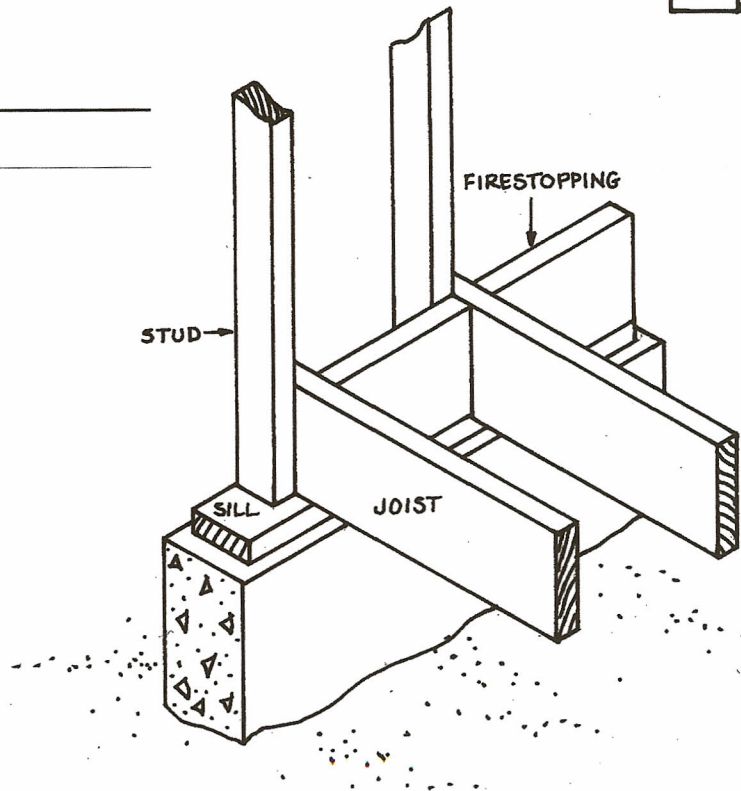


Figure 17. Joist Supported on Ledger

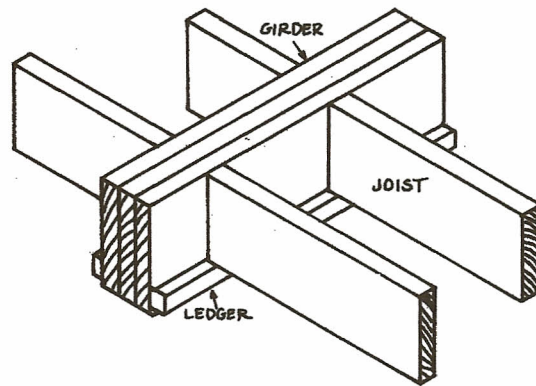


Figure 18. Joist Supported by Metal Framing Anchors

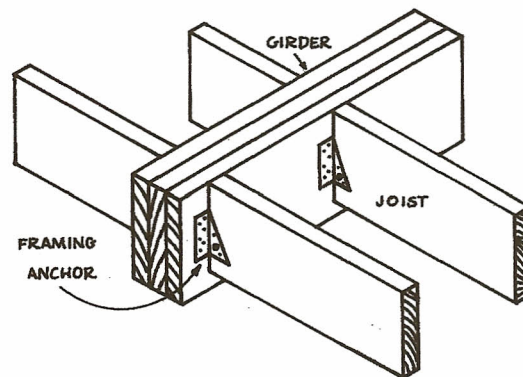


Figure 19. Joists Resting on Girder

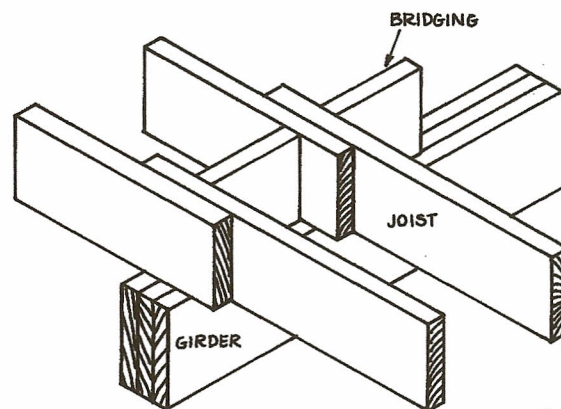


Figure 20. Joists Resting on Steel Beam

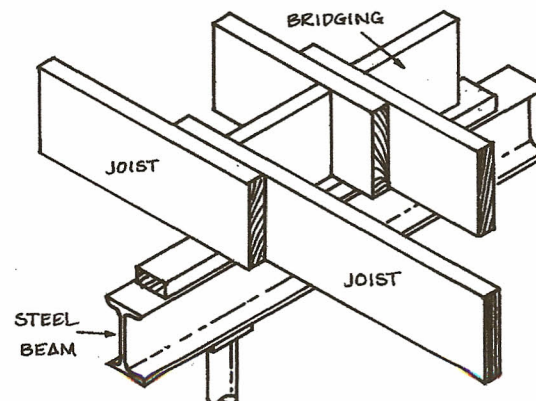


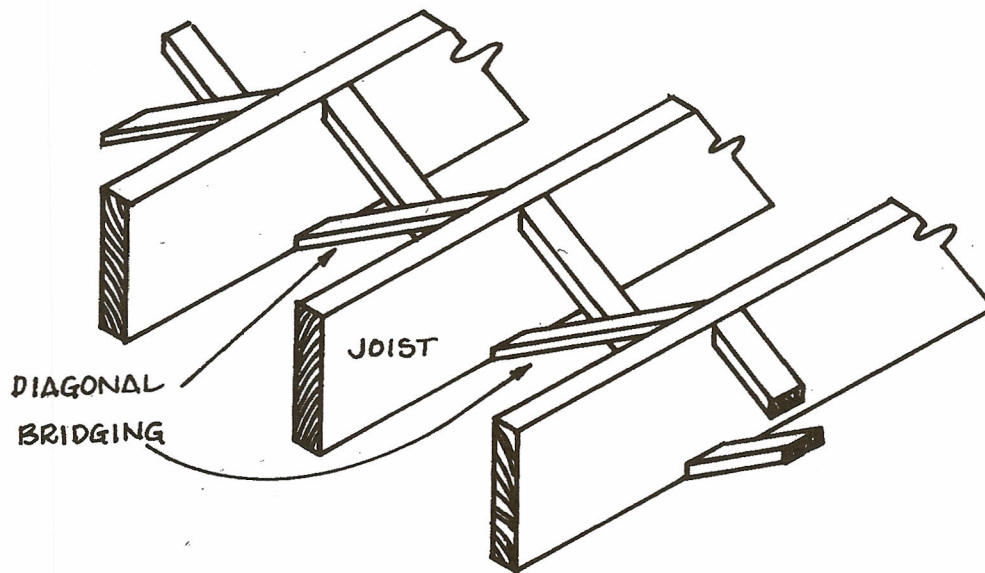
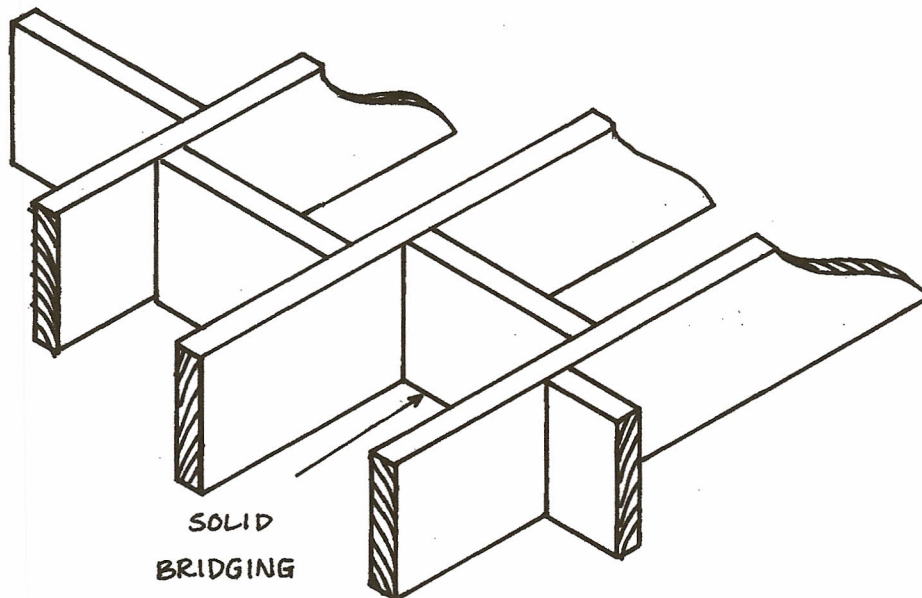
Figure 21. Diagonal Bridging of Floor Joists**Figure 22. Solid Bridging of Floor Joists**

Figure 23. Framing of Tail Joists on Ledger Strip

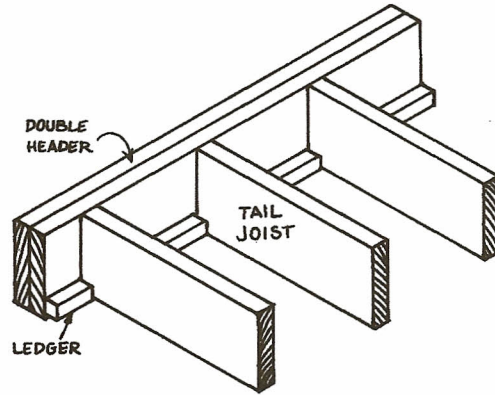


Figure 24. Framing of Tail Joists by Framing Anchors

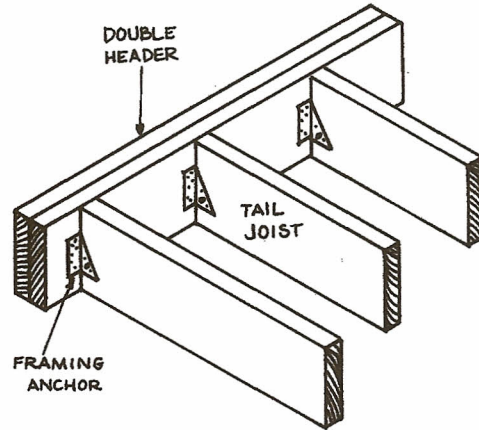


Figure 25. Framing of Header to Trimmer by Joist Hangers

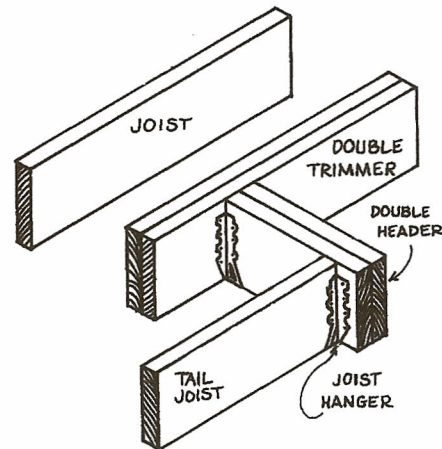


Figure 26. Notching and Boring of Joists

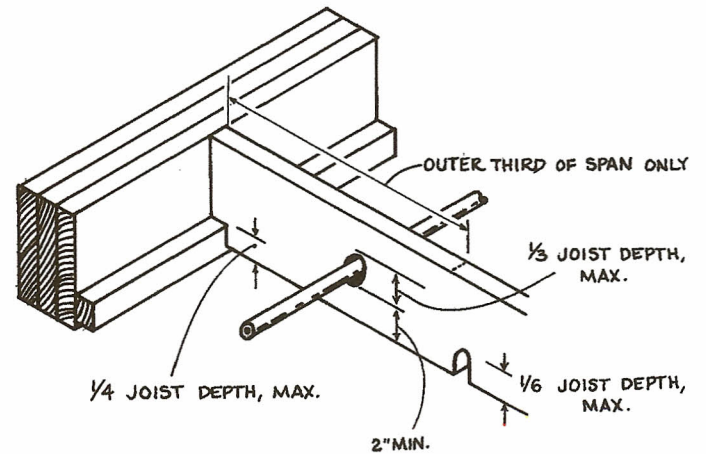


Figure 27. Framing Over Bearing Partition, Platform Construction

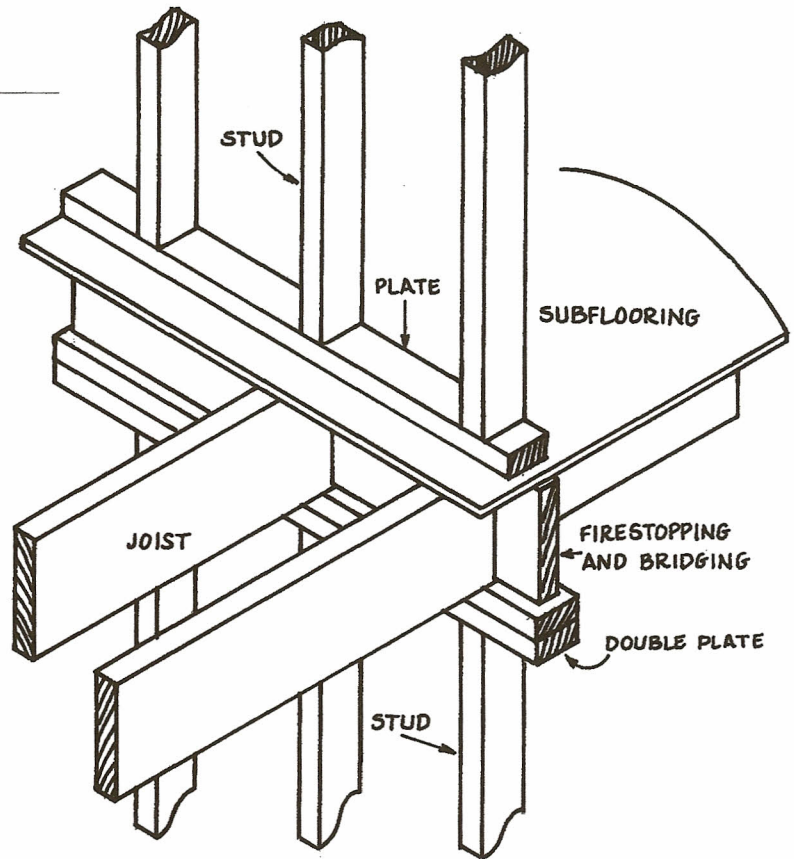


Figure 28. Framing Over Bearing Partition, Balloon Construction

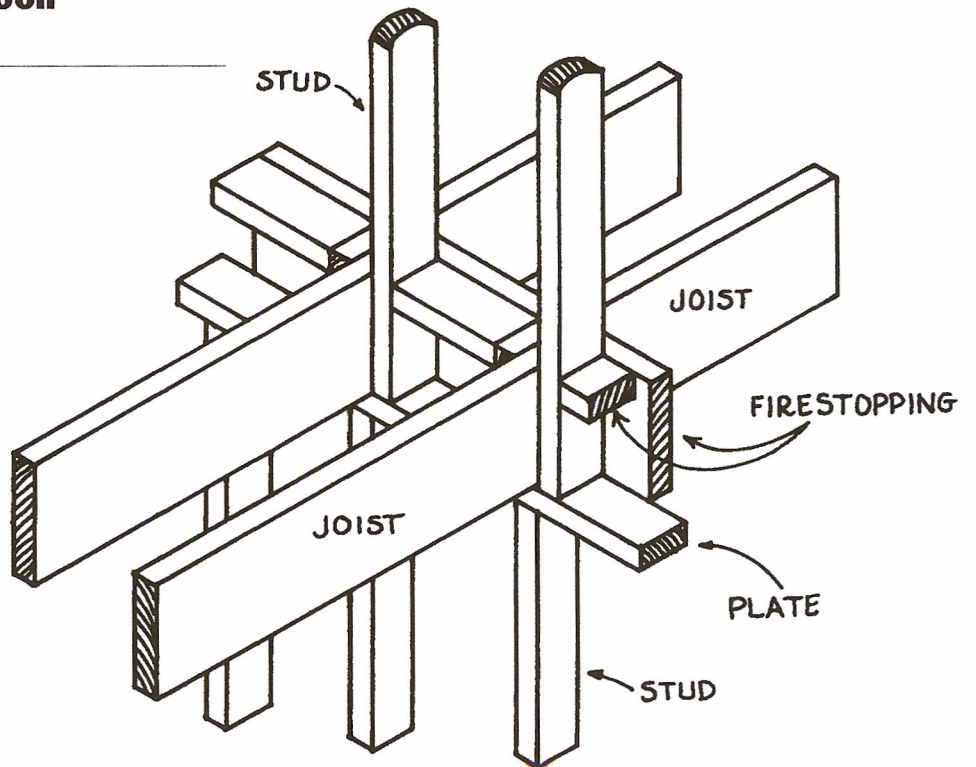


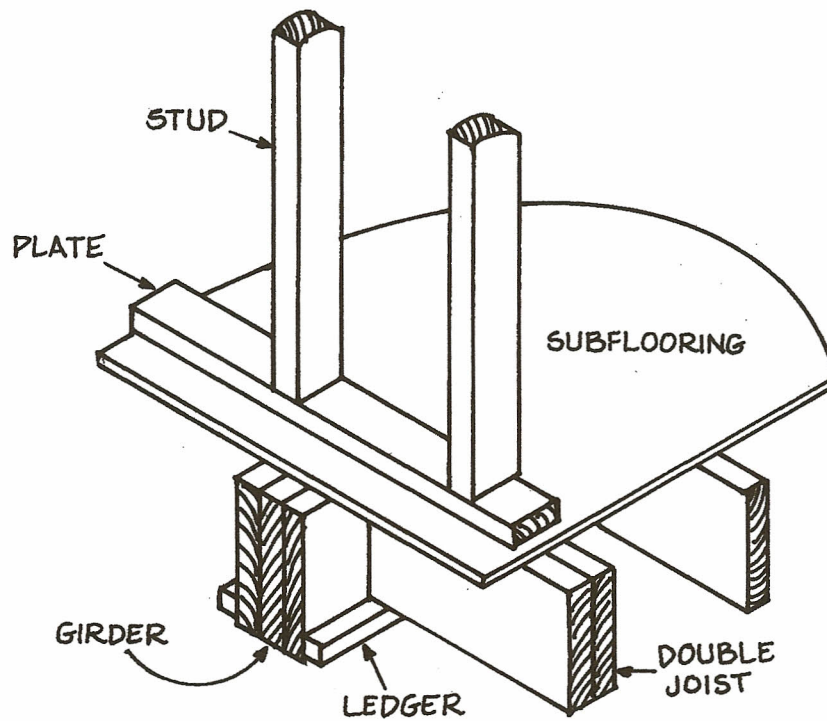
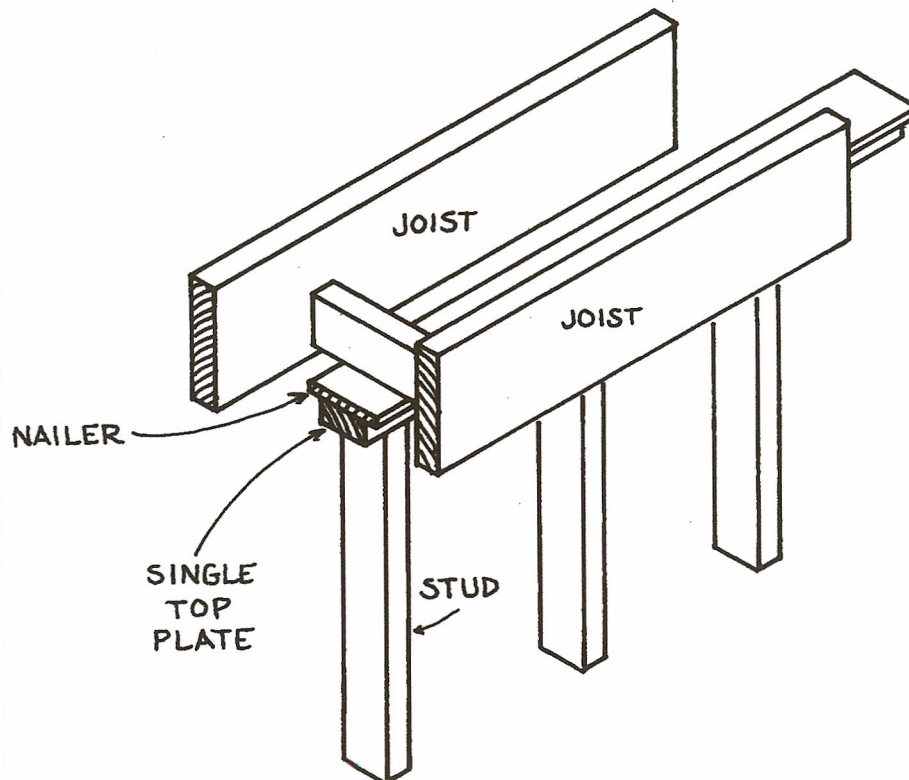
Figure 29. Framing Under Non-Bearing Partition**Figure 30. Attachment of Non-Bearing Partition to Ceiling Framing**

Figure 31. Interior Stairway Framing

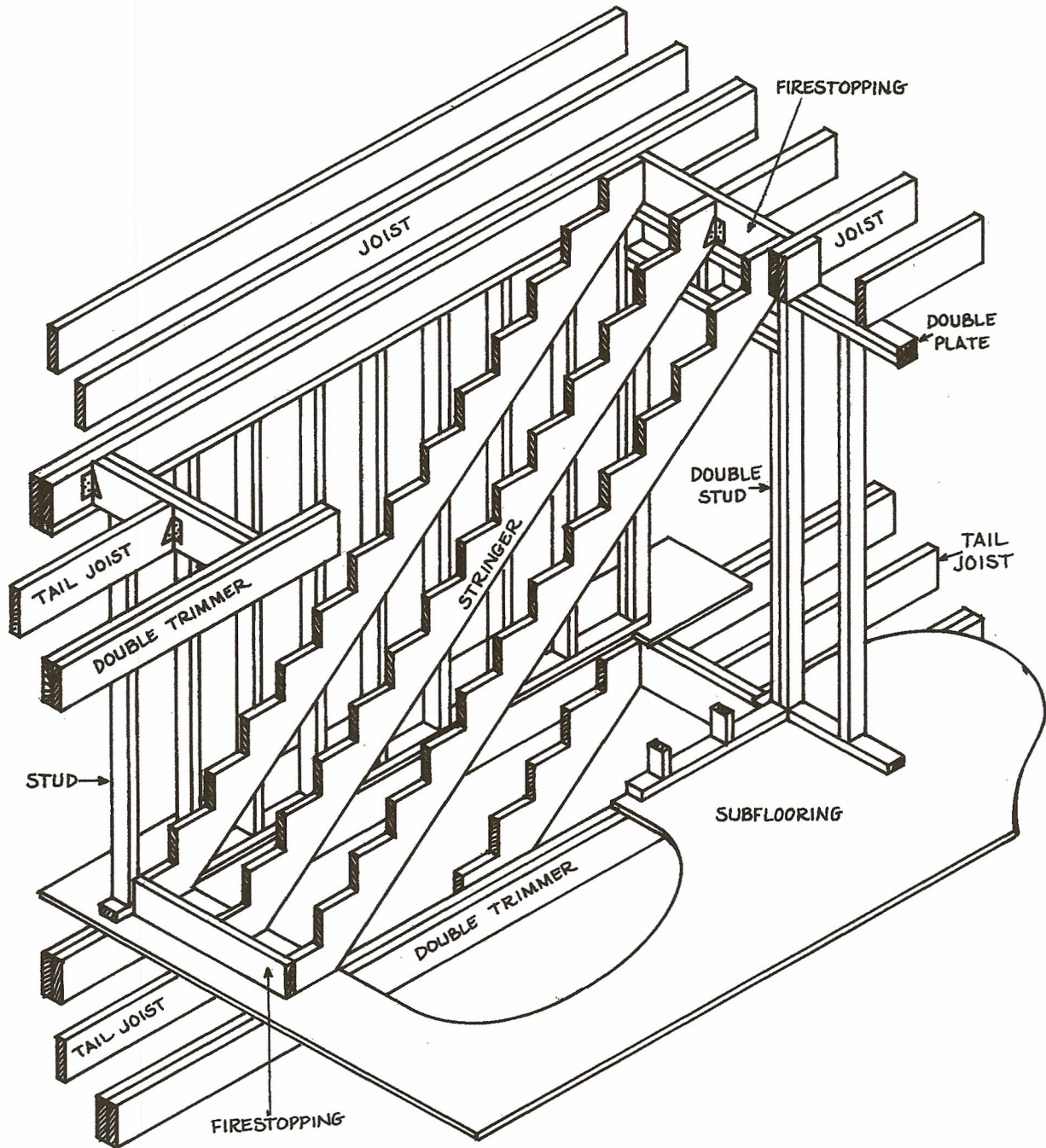


Figure 32. Stairway With a Landing

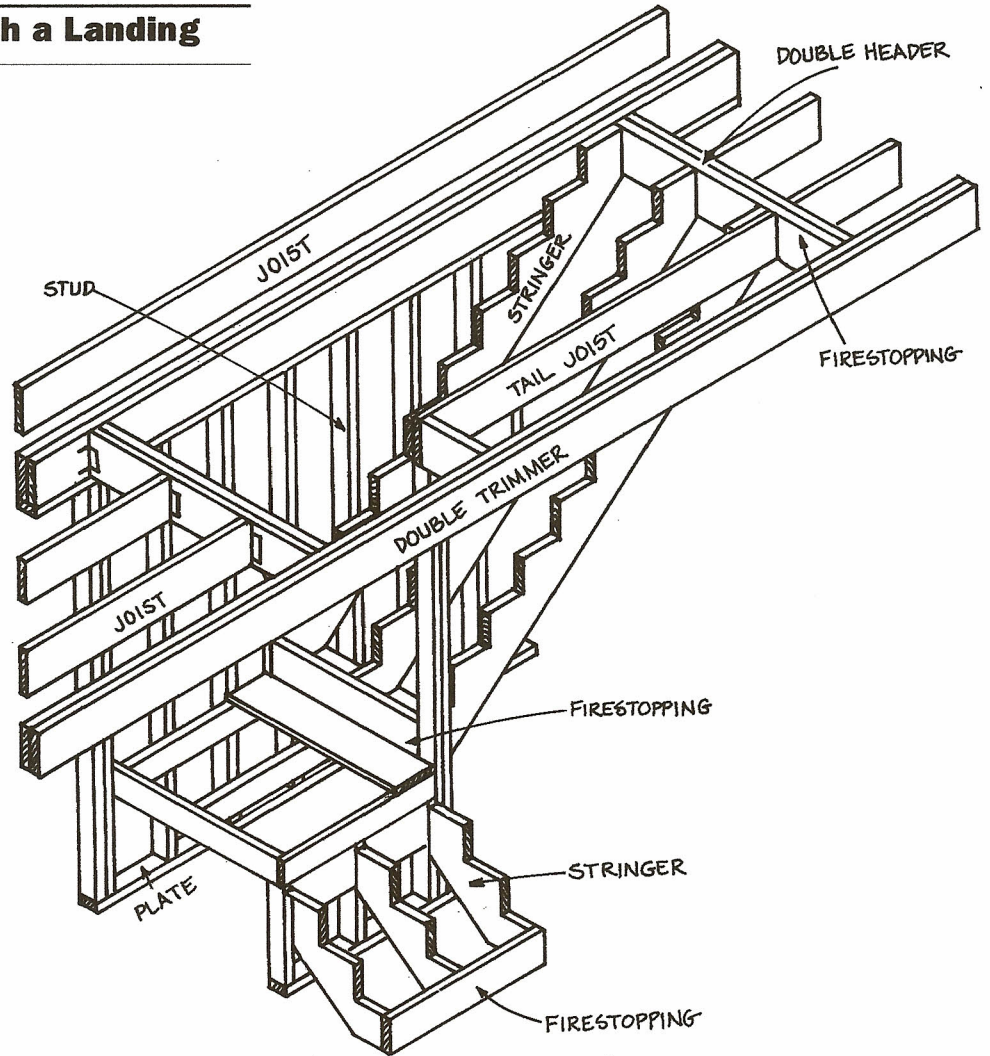


Figure 33. Framing Supporting Bath Tub

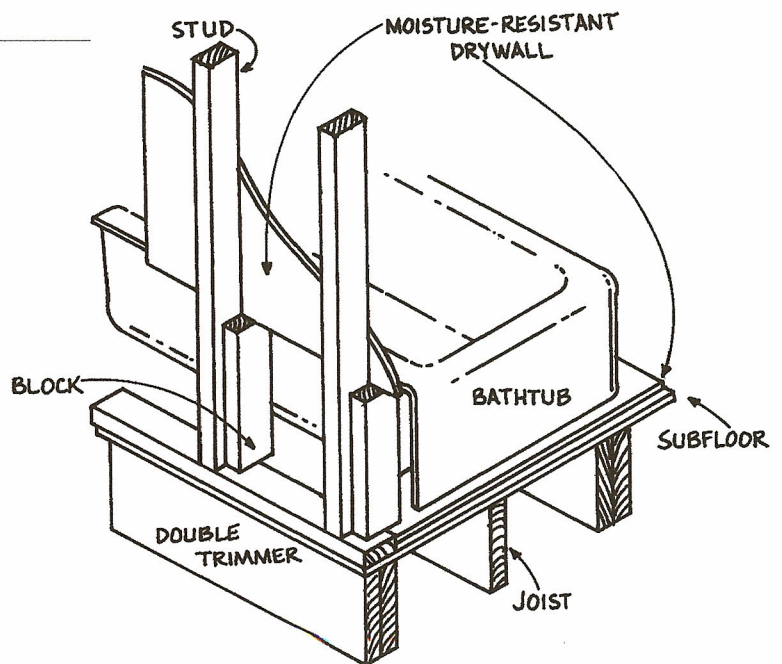


Figure 34. Second Floor Framing, Exterior Wall

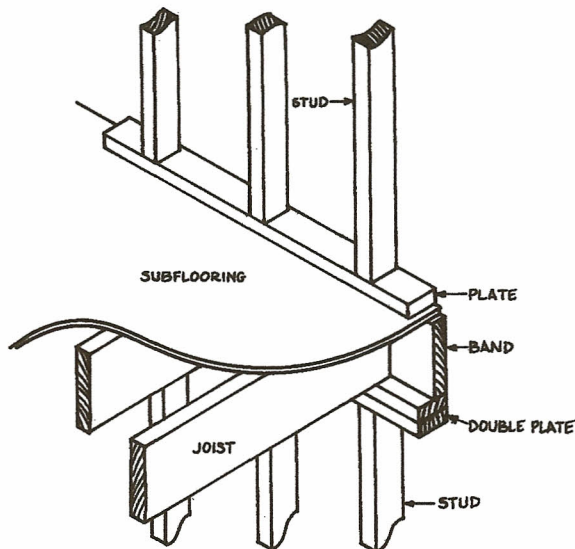


Figure 35. Second Floor Overhang of Exterior Wall, Joists at Right Angles to Supporting Walls

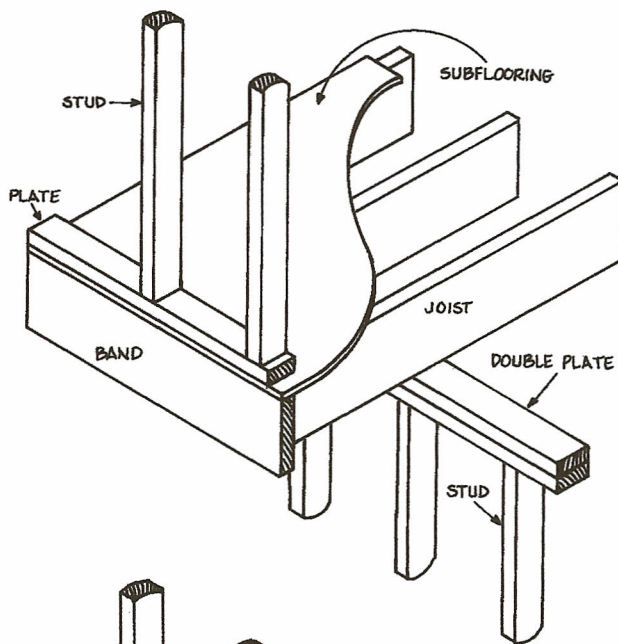


Figure 36. Second Floor Overhang of Exterior Wall, Joists Parallel to Supporting Walls

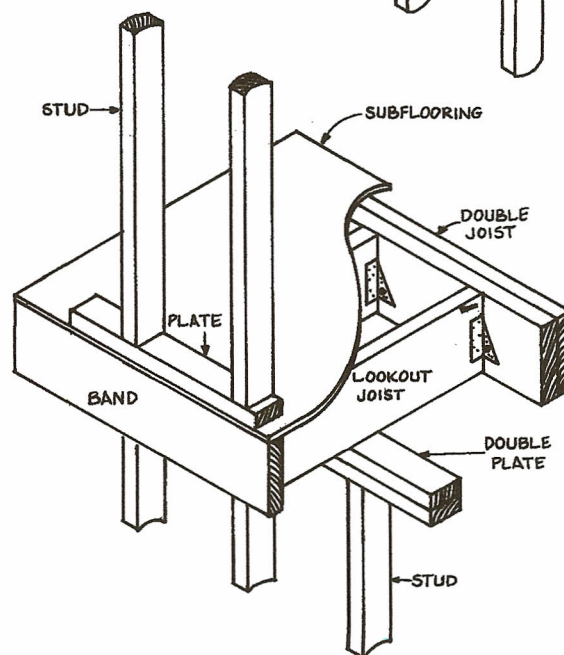


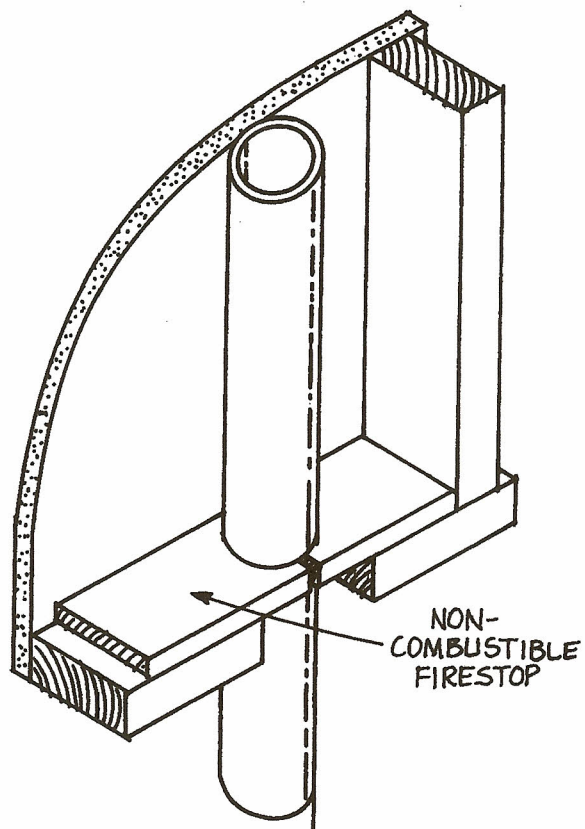
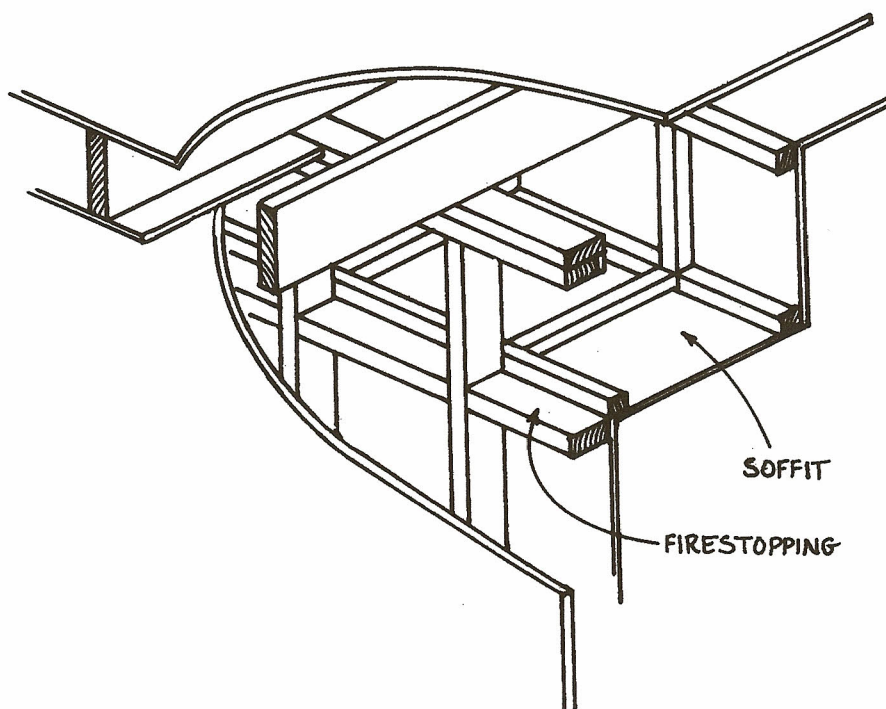
Figure 37. Firestopping Around Pipes**Figure 38. Firestopping of Dropped Ceilings**

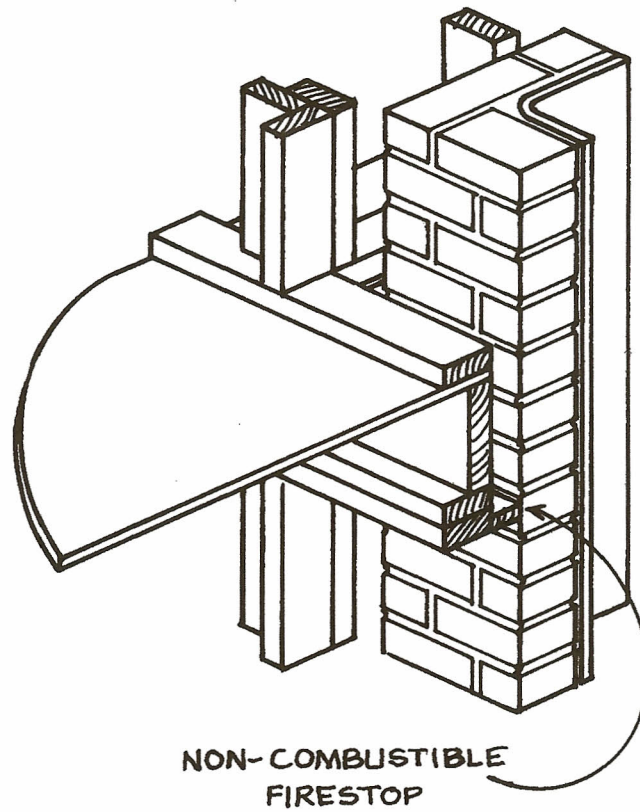
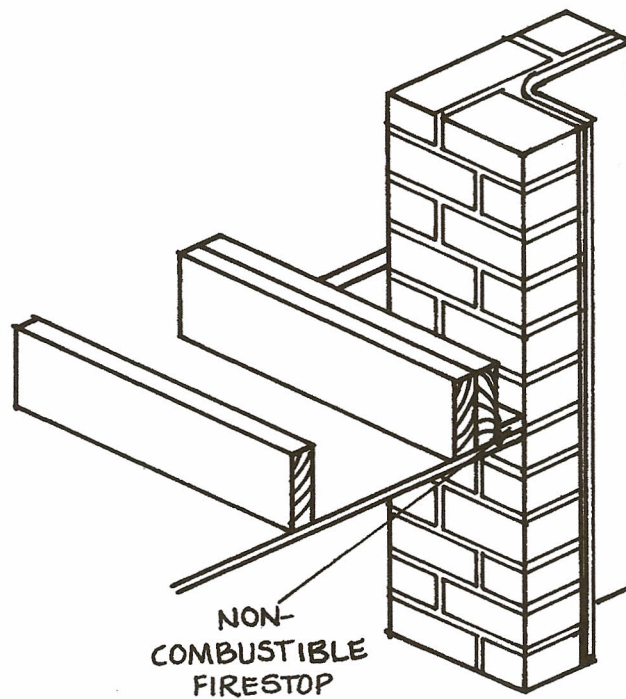
Figure 39a. Firestopping of Masonry Walls - Floor**Figure 39b. Firestopping of Masonry Walls - Ceiling**

Figure 40. Draftstopping of Trussed Floors

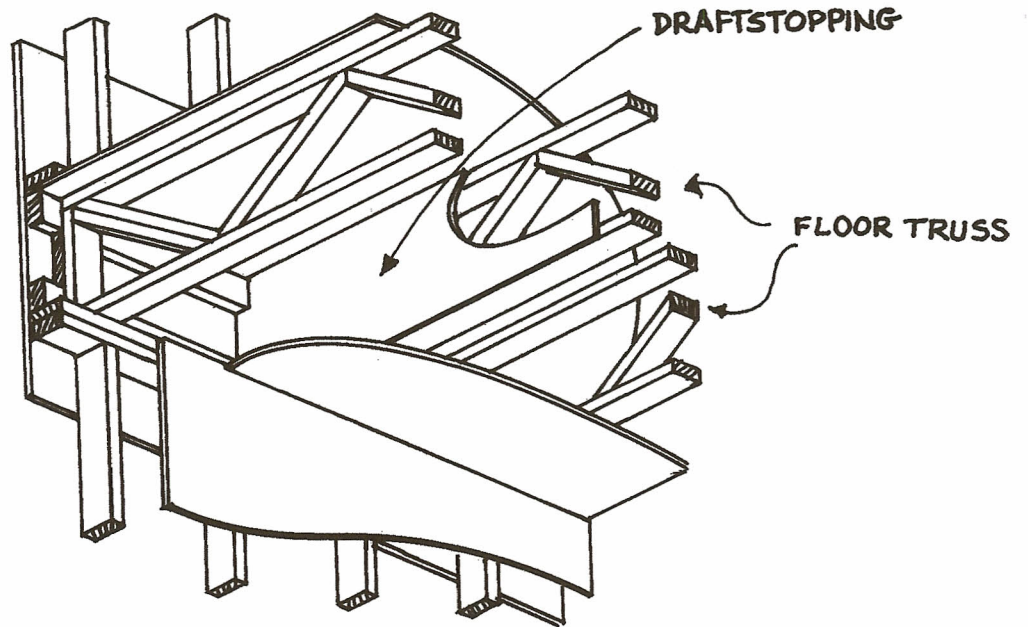


Figure 41. Multiple Studs at Corners

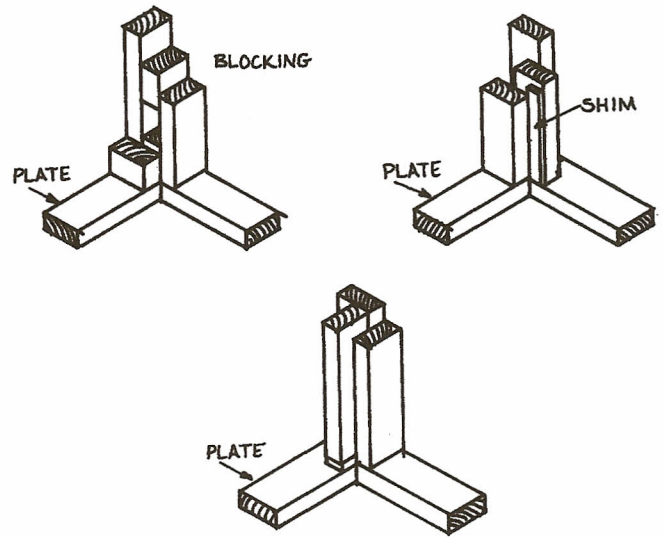


Figure 42. Wall Framing at Intersecting Partitions

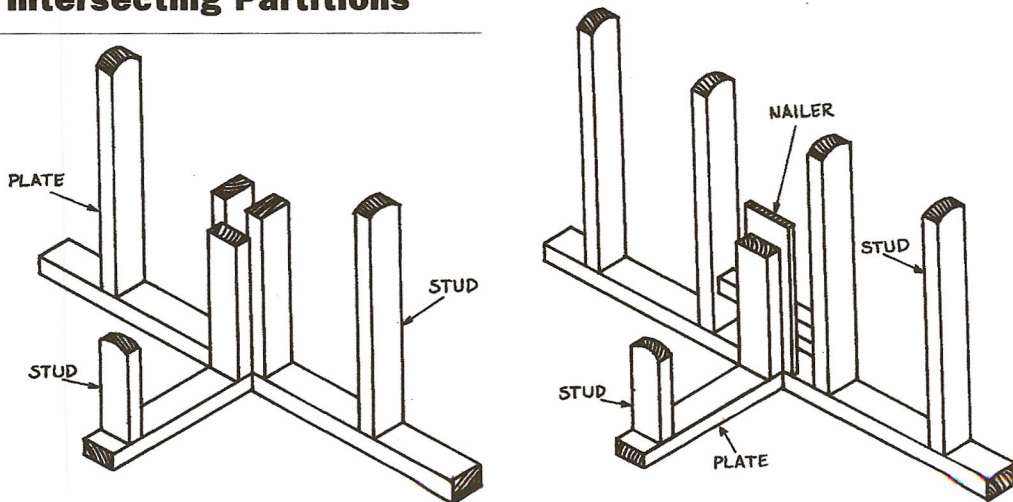


Figure 43. Exterior Wall Openings, Header Details with Cripple Studs

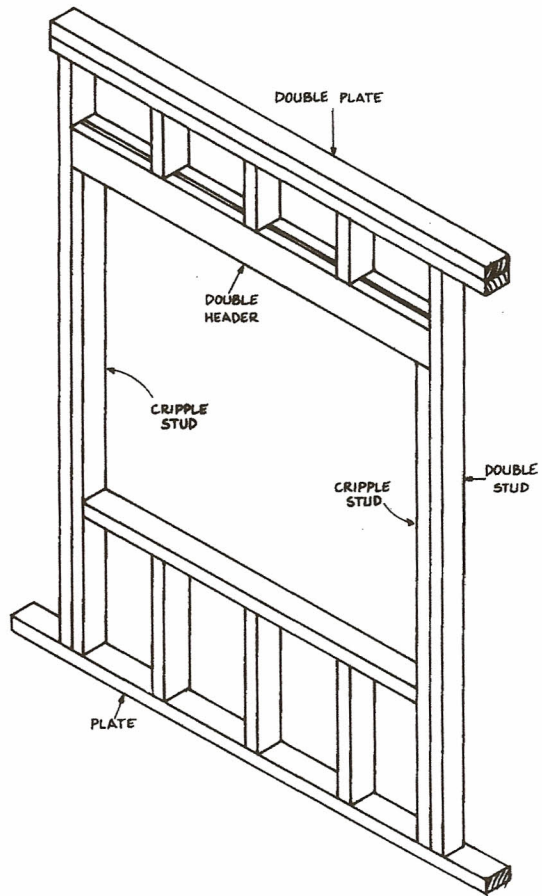


Figure 44. Exterior Wall Openings, Header Details with Joist Hangers

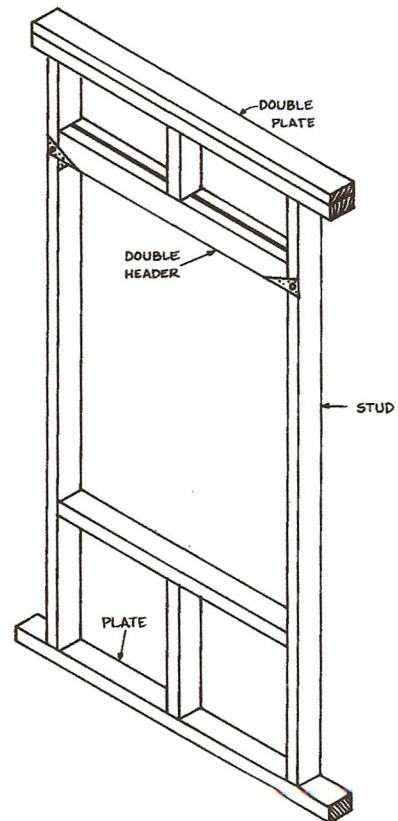


Figure 45. Framing of Bay Window

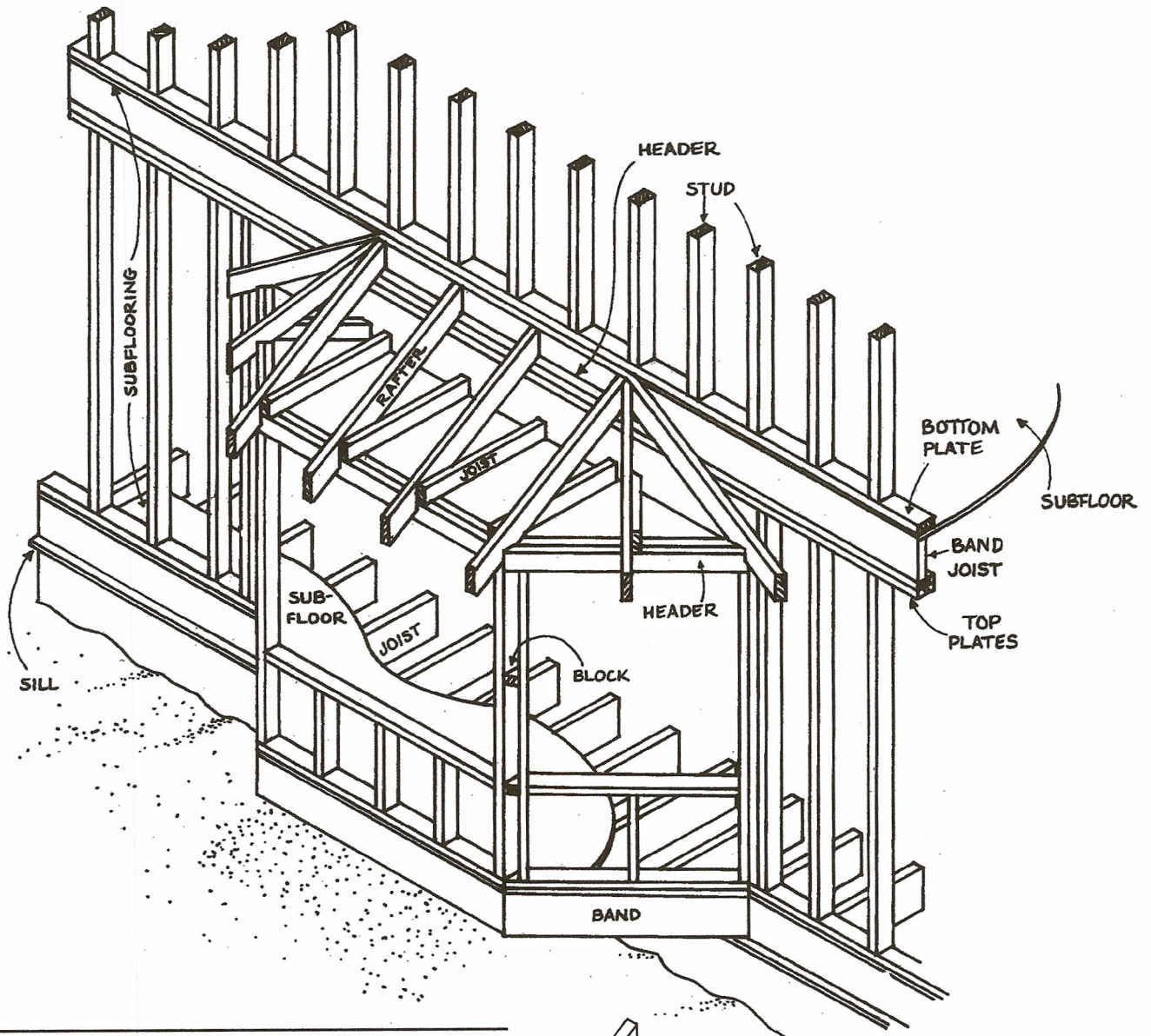


Figure 46. Wall Framing at Gable Ends

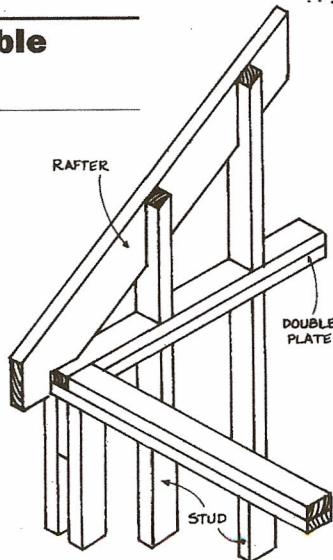


Figure 47a. Wall and Floor Framing at Fireplace

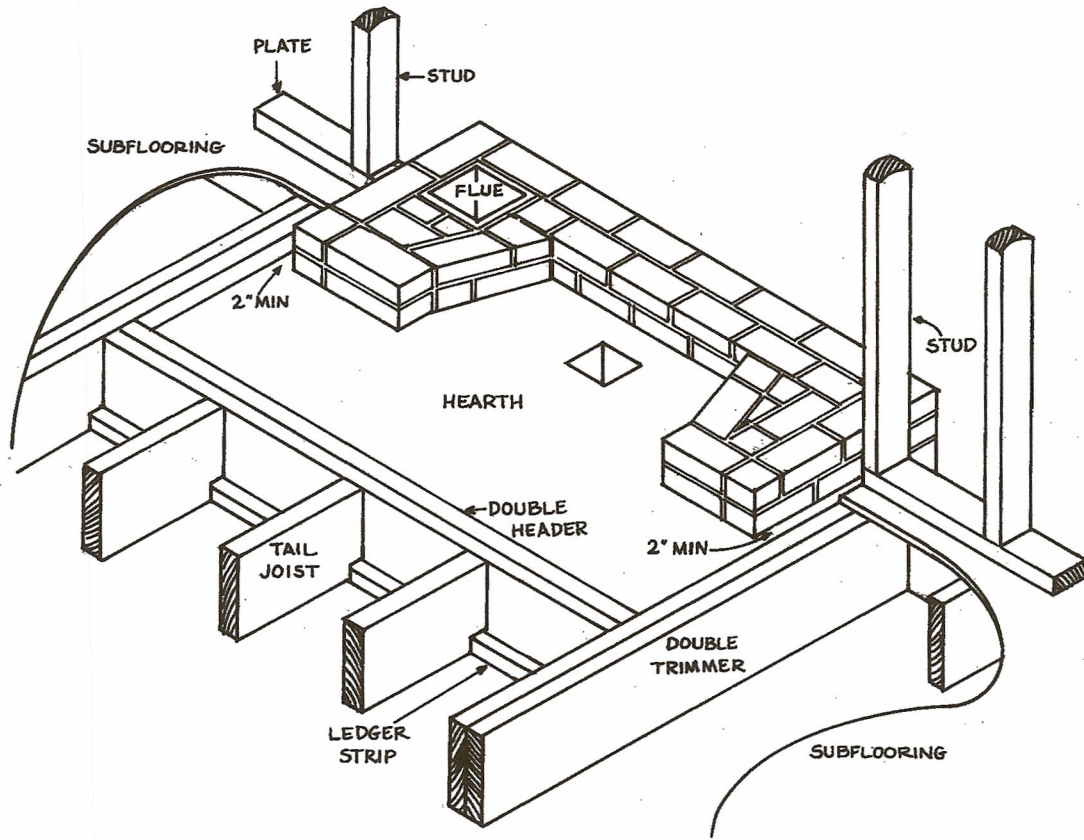


Figure 47b. Hearth Centering Detail

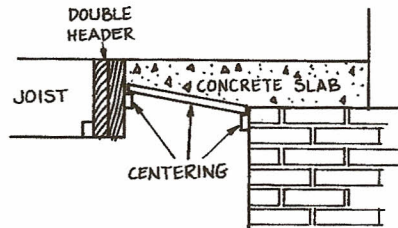


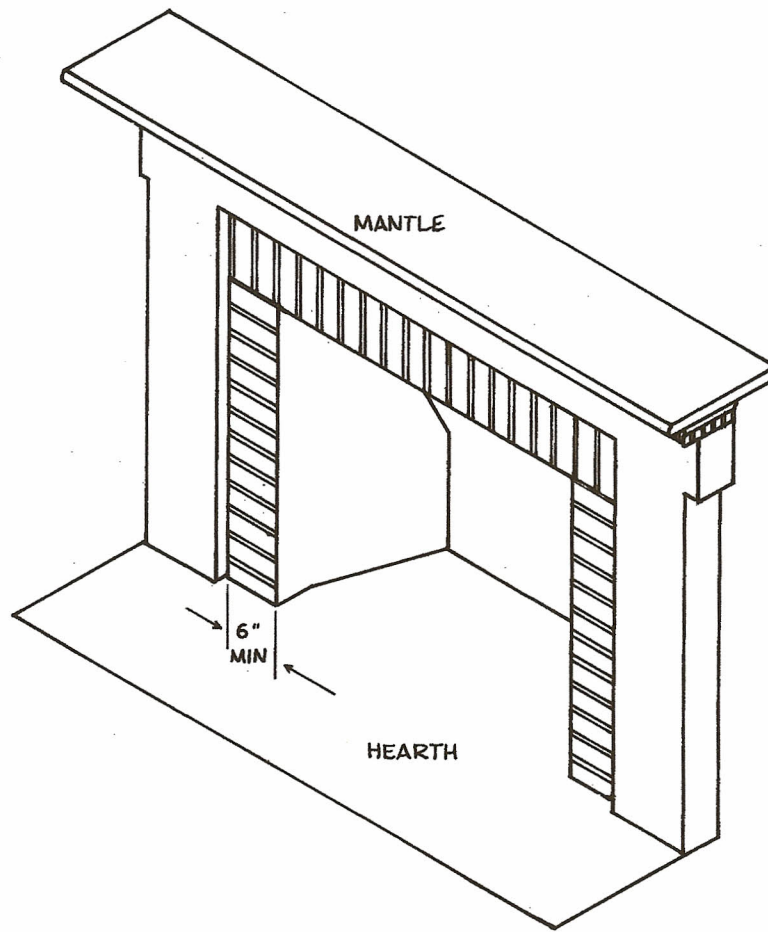
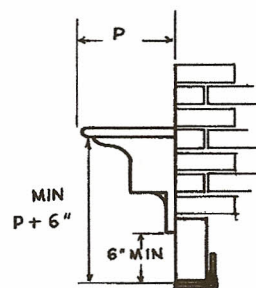
Figure 48a. Clearance of Fireplace Trim**Figure 48b. Section Through Mantle**

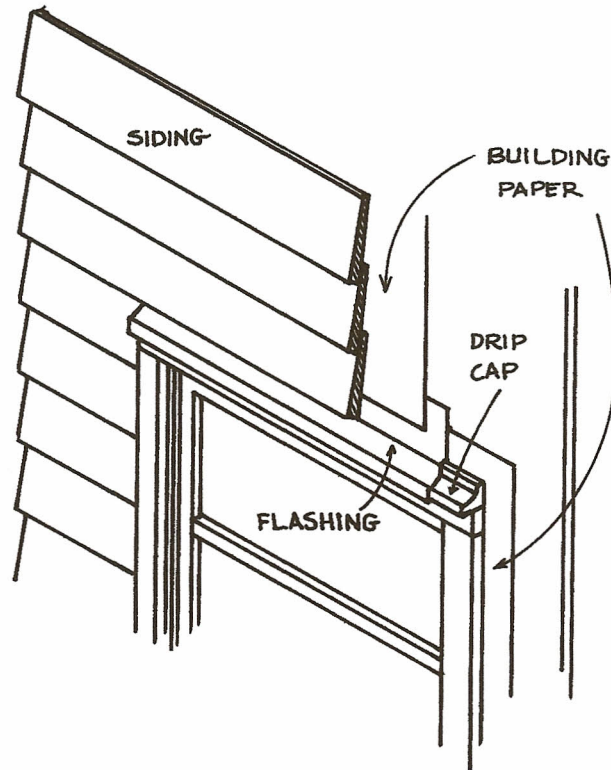
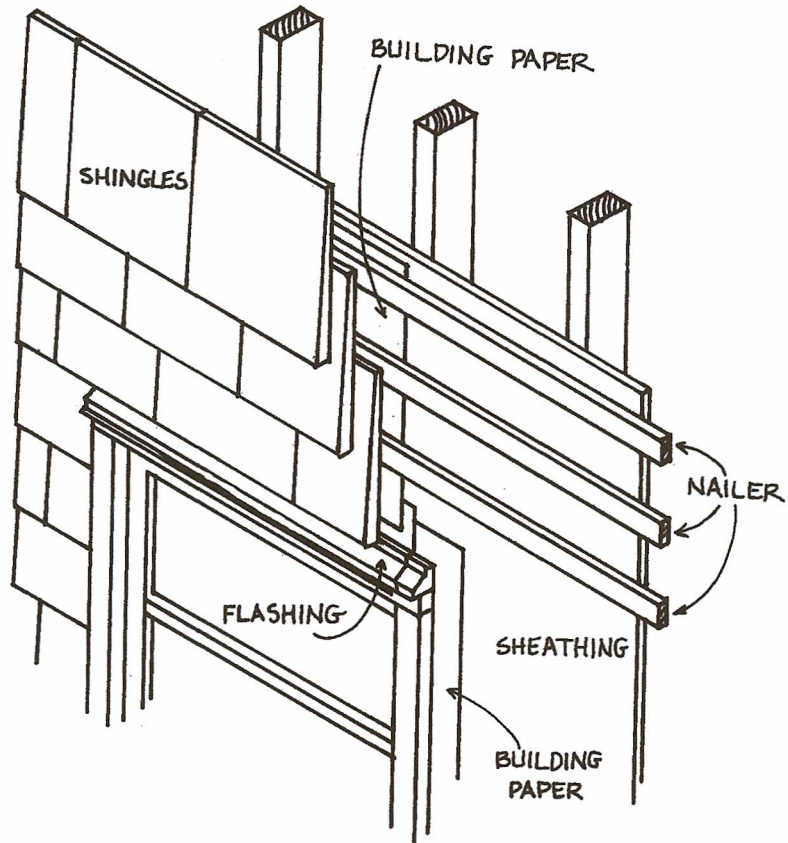
Figure 49. Building Paper and Siding Application**Figure 50. Application of Wood Shingles**

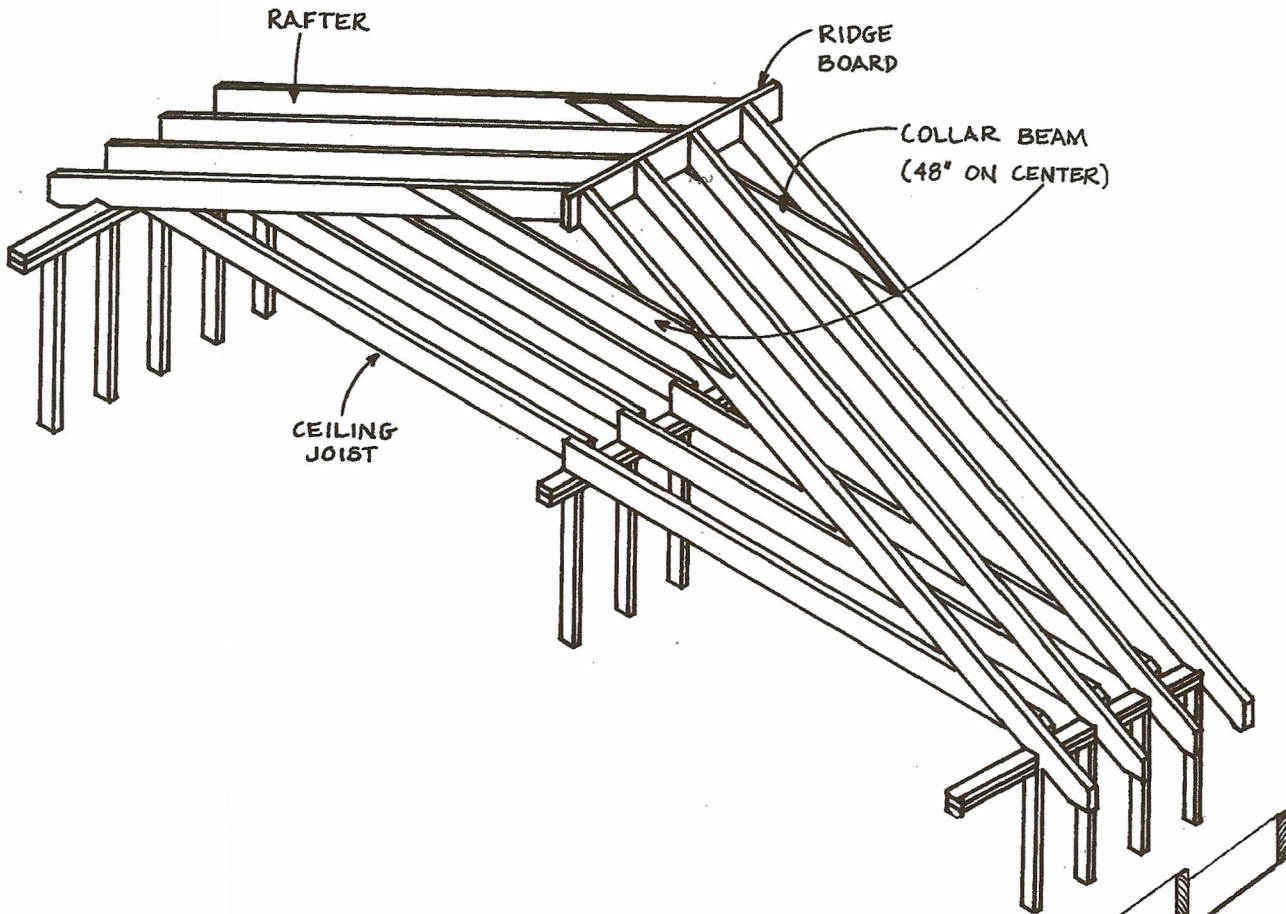
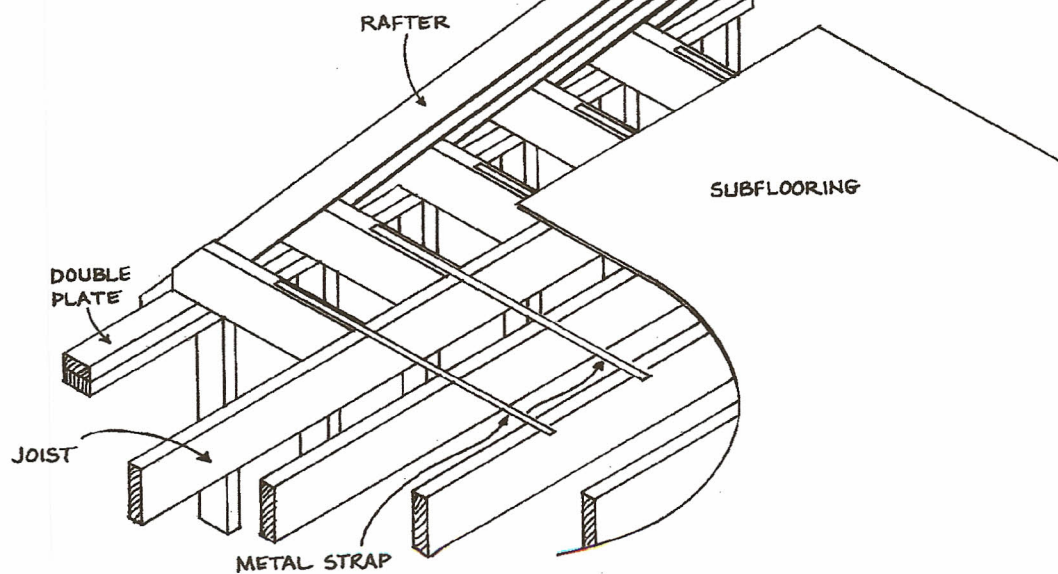
Figure 51. Roof Framing Ceiling Joists Parallel to Rafters**Figure 52. Roof Framing, Ceiling Joists Perpendicular to Rafters**

Figure 53. Roof Framing Gable Overhang

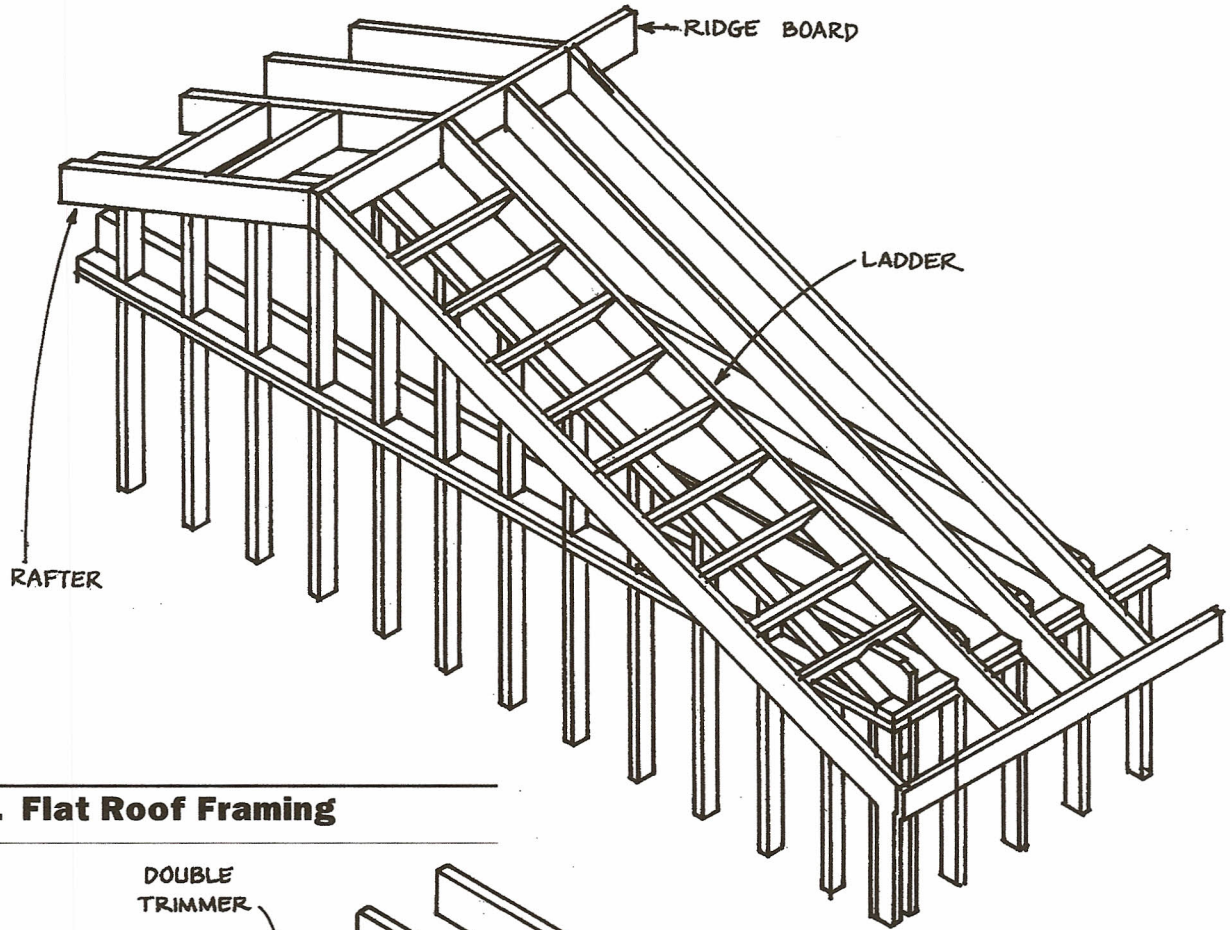


Figure 54. Flat Roof Framing

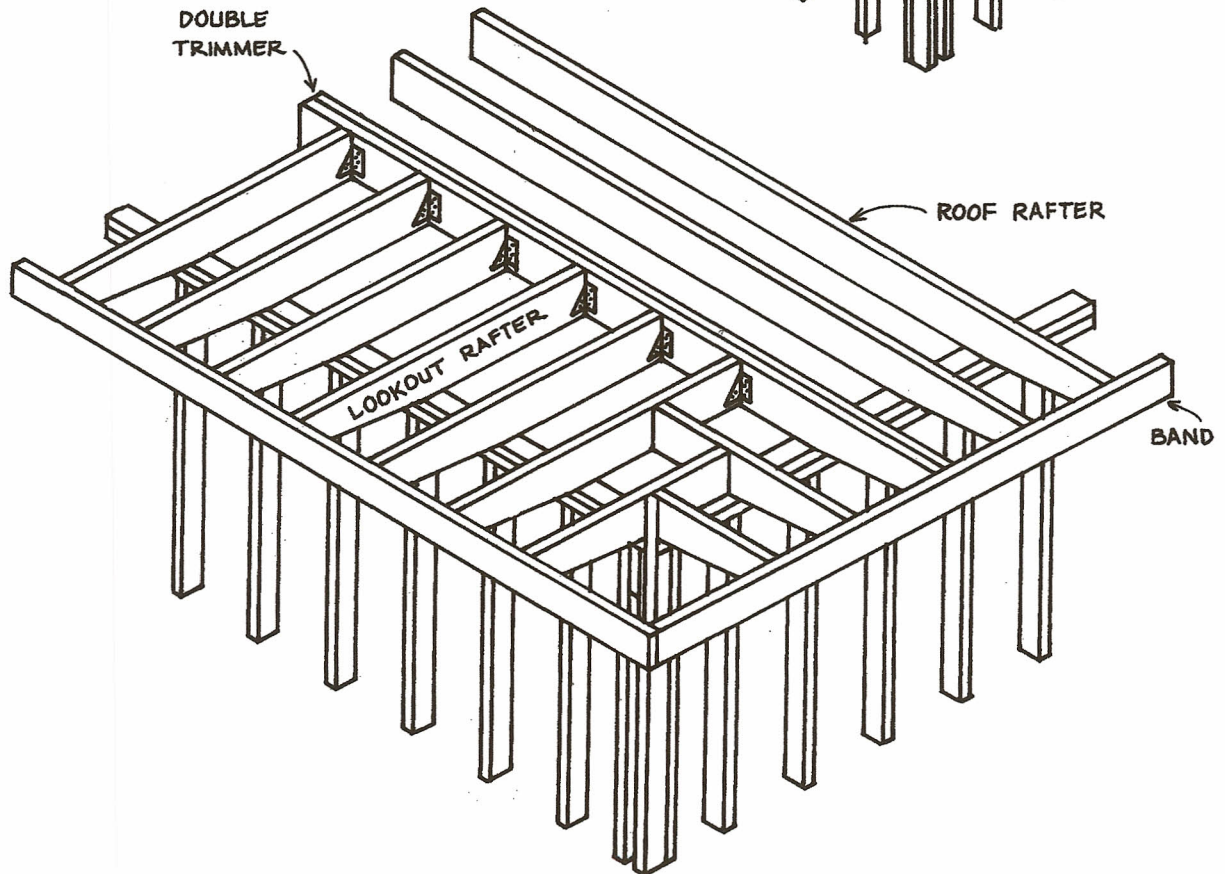


Figure 55. Valley Rafter Roof Framing

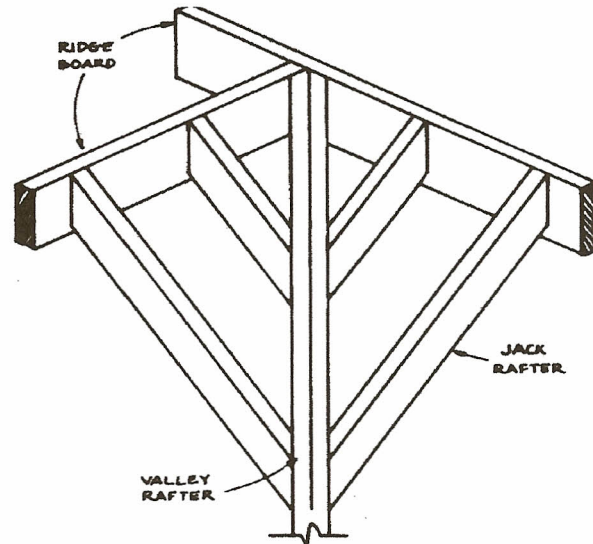


Figure 56. Hip Rafter Roof Framing

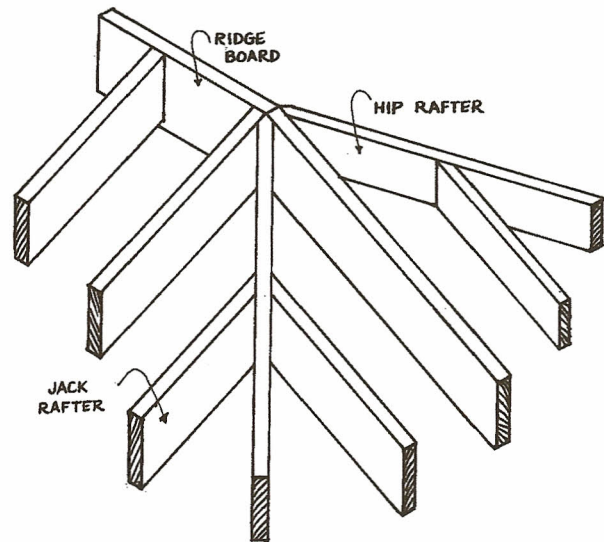


Figure 57. Roof Framing at Eave

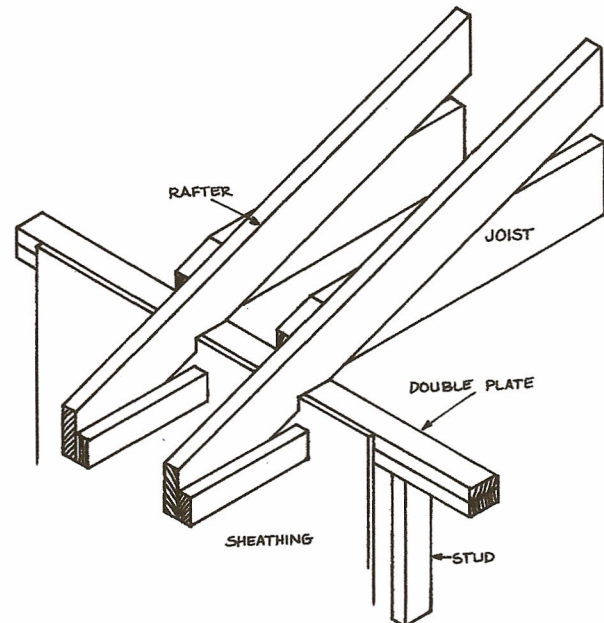


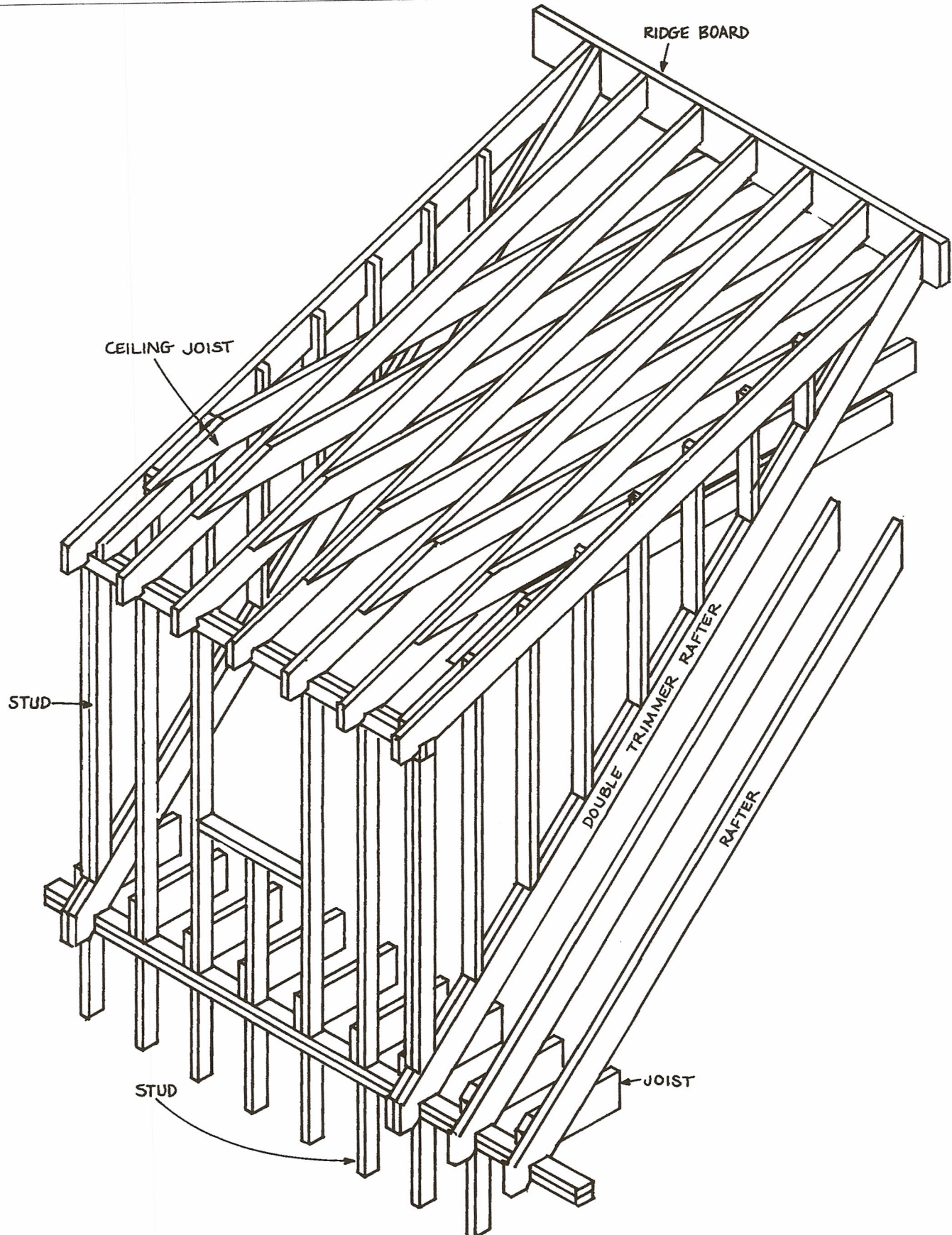
Figure 58. Shed Dormer Roof Framing

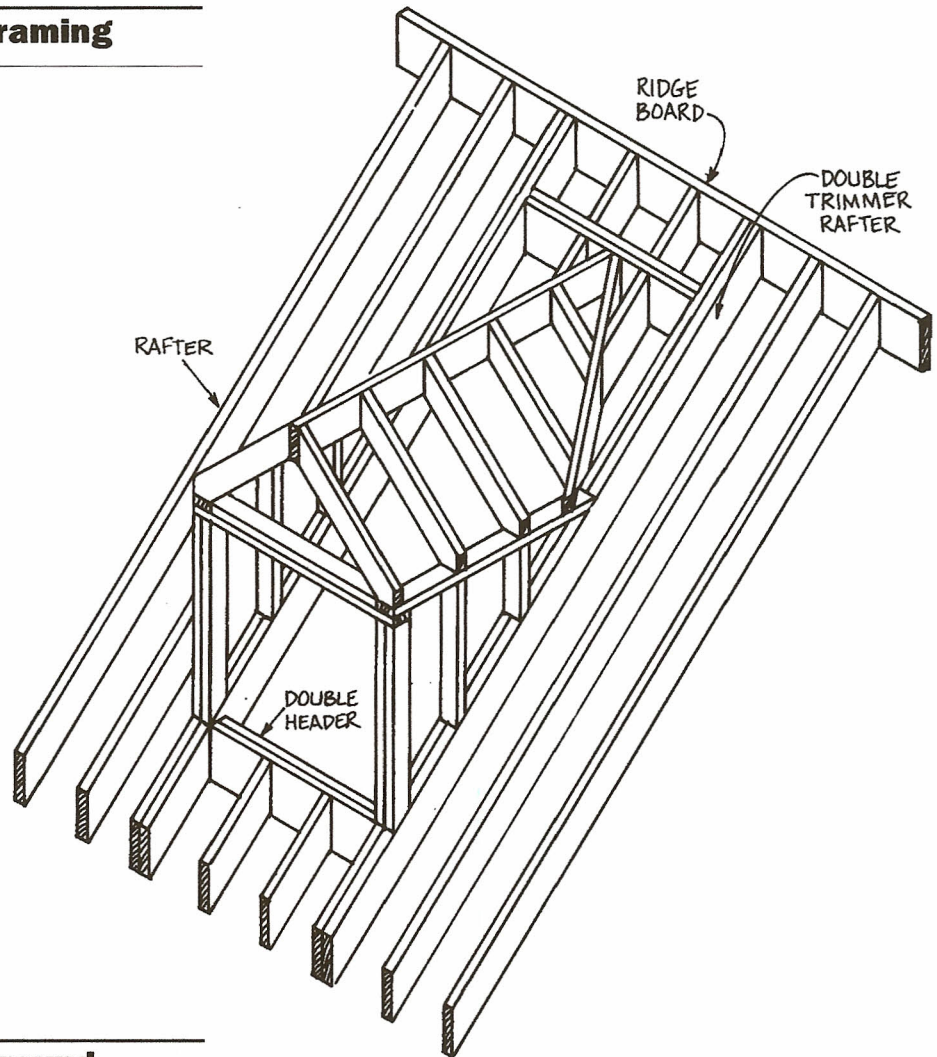
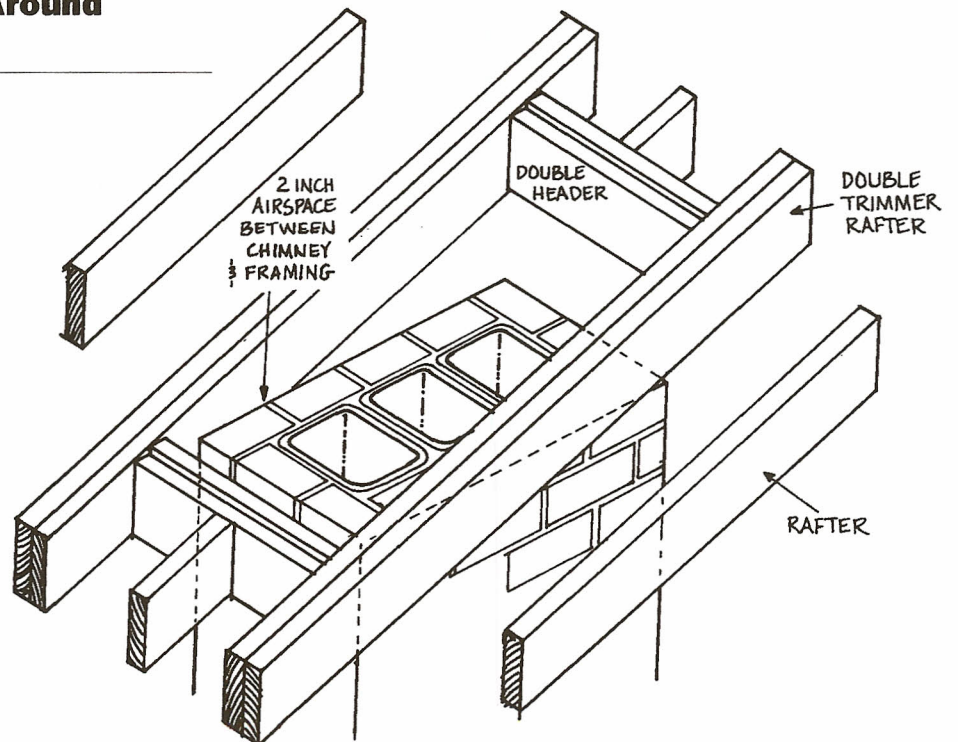
Figure 59. Gable Dormer Framing**Figure 60. Roof Framing Around Chimney**

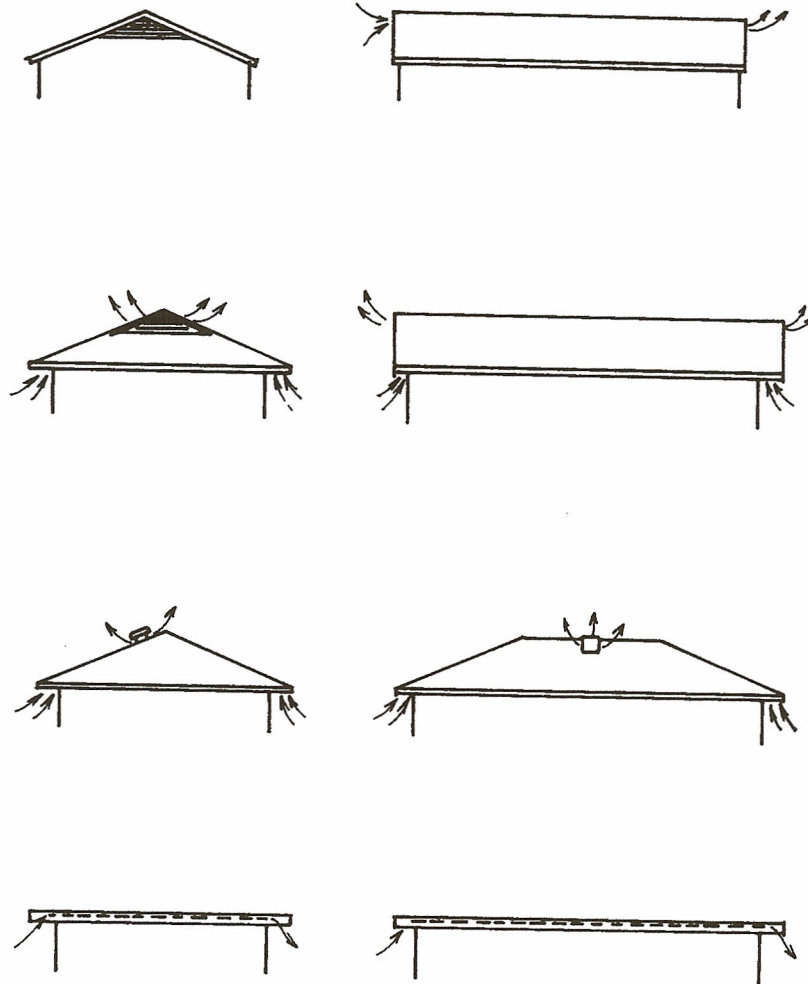
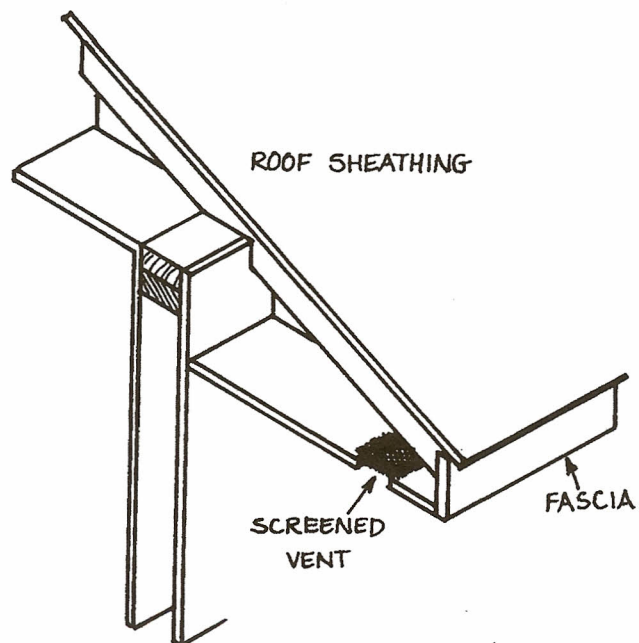
Figure 61. Roof Ventilation Requirements**Figure 62. Ventilating Eave Overhangs**

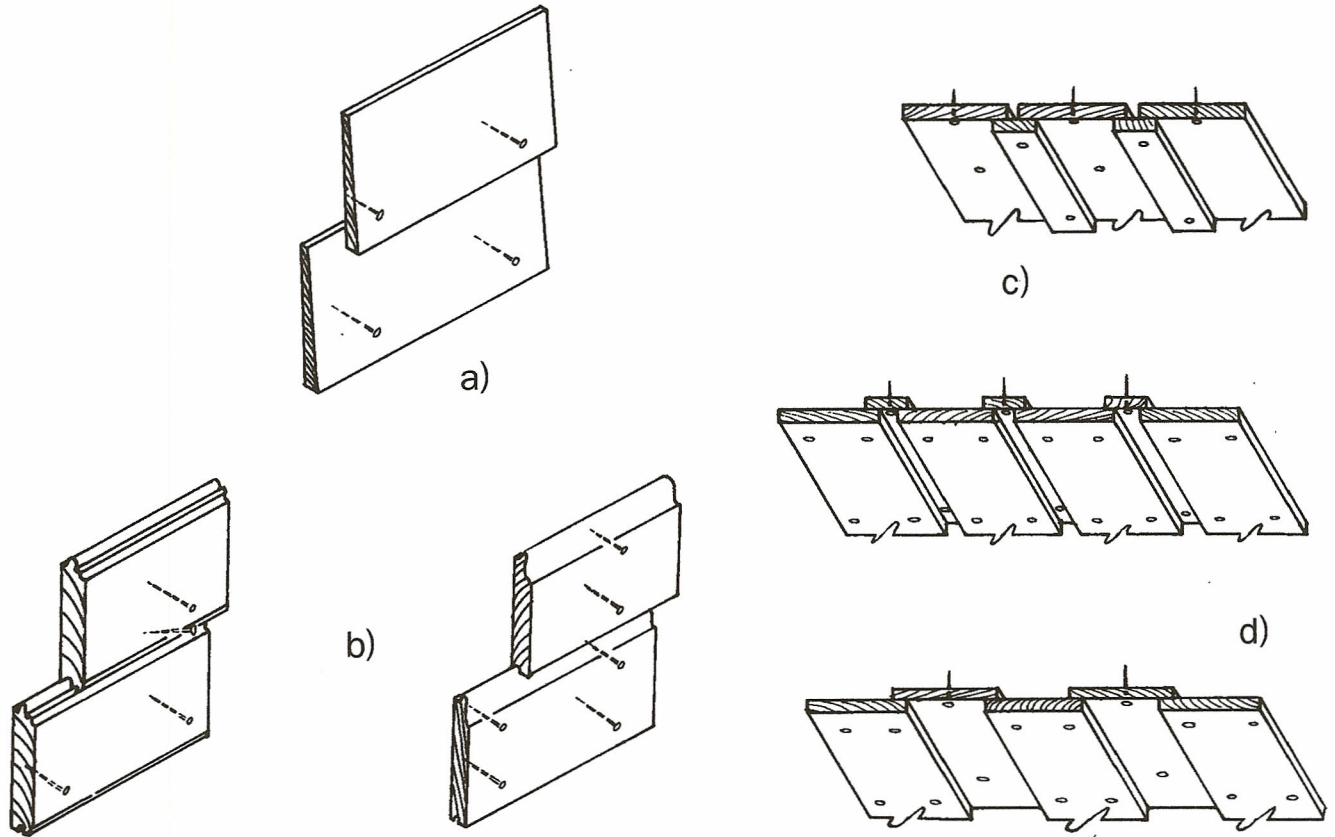
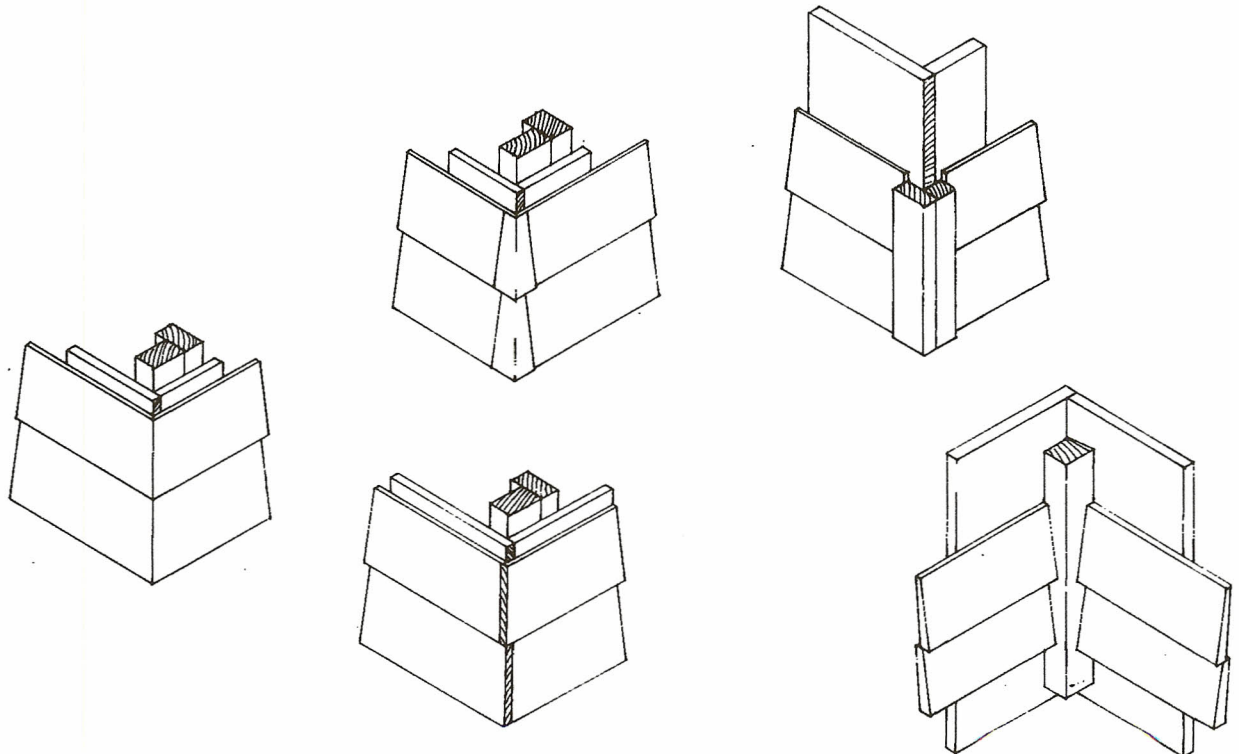
Figure 63. Wood Siding Patterns and Nailing**Figure 64. Corner Treatments for Wood Siding**

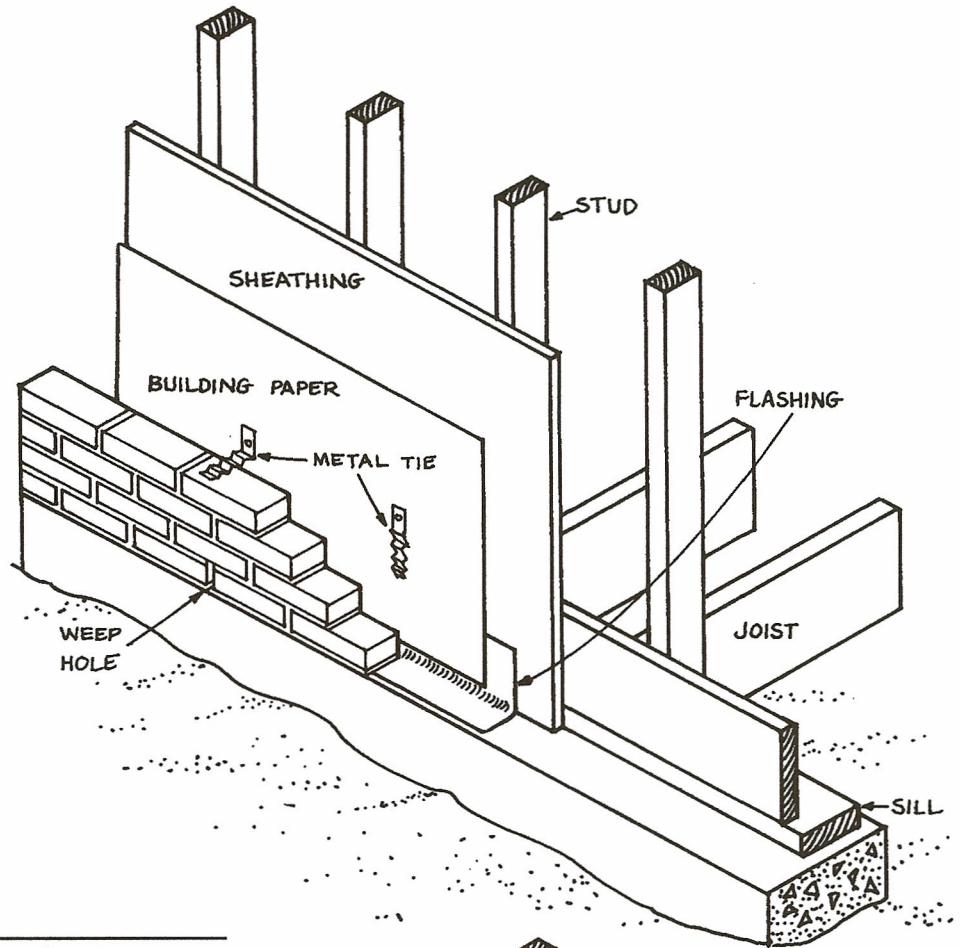
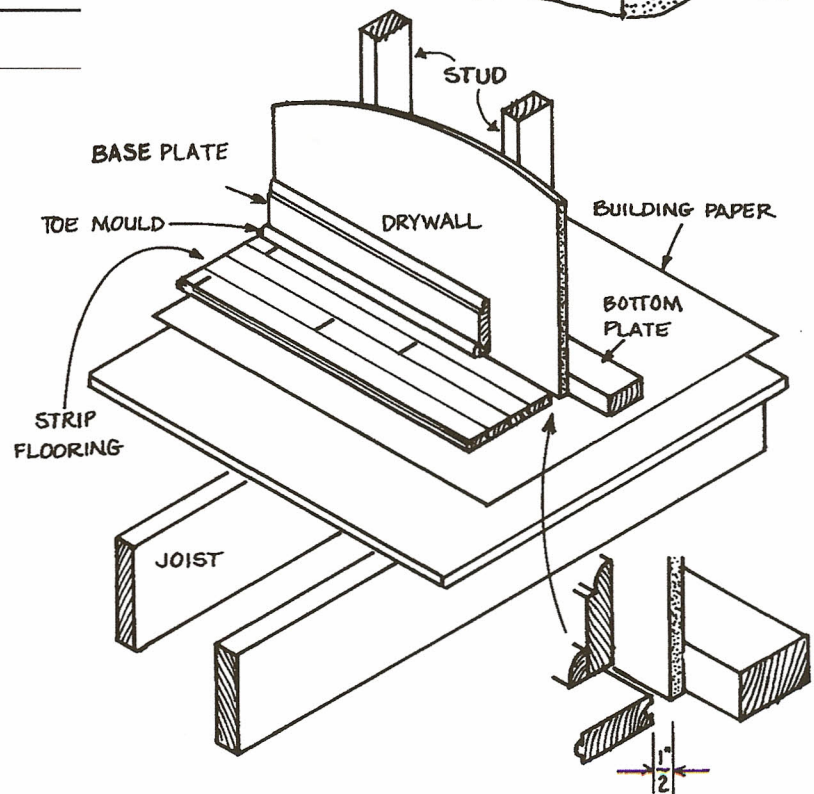
Figure 65. Application of Masonry Veneer to Wood Framing**Figure 66. Wood Strip Flooring**

Figure 67. Wood Deck

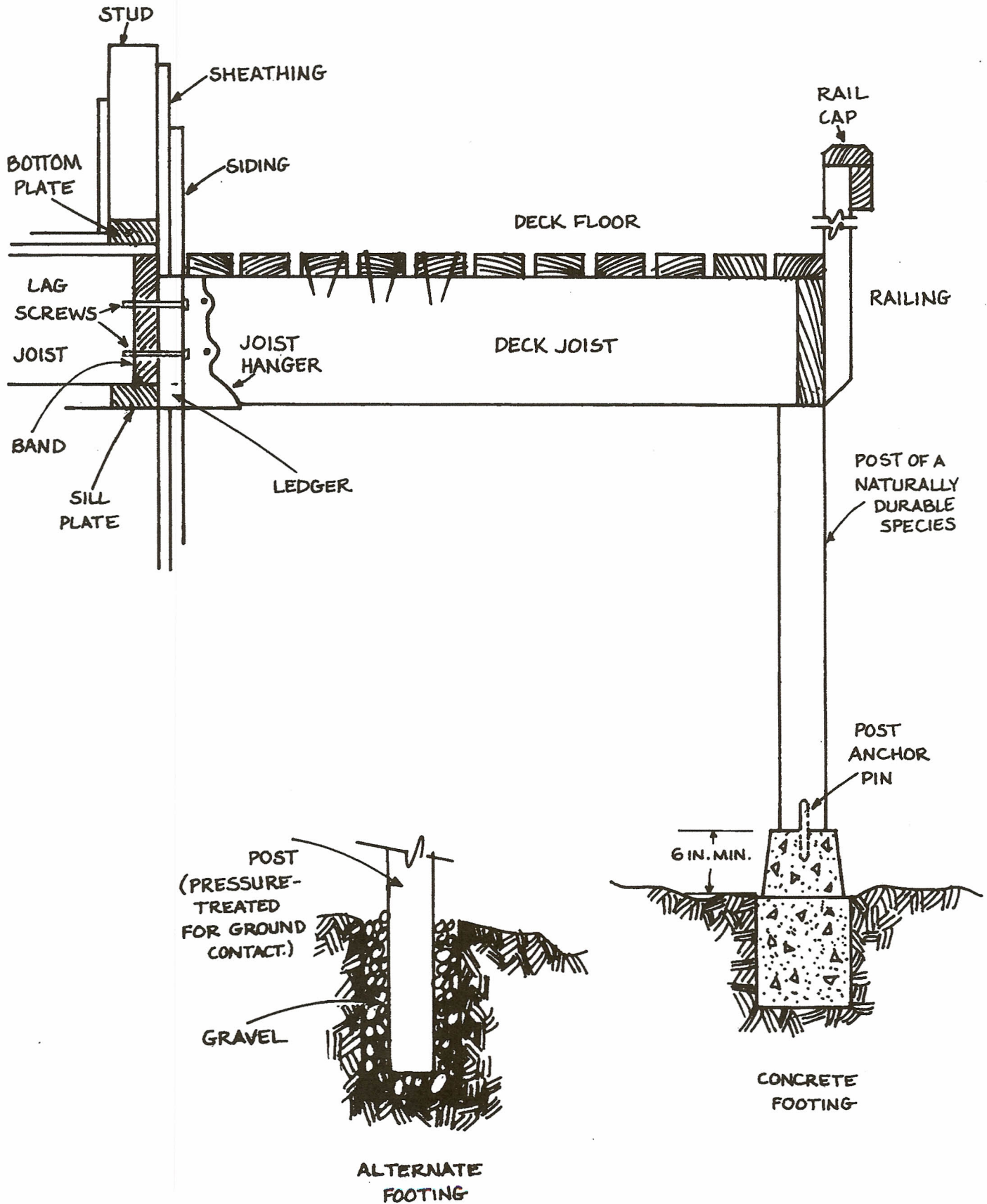
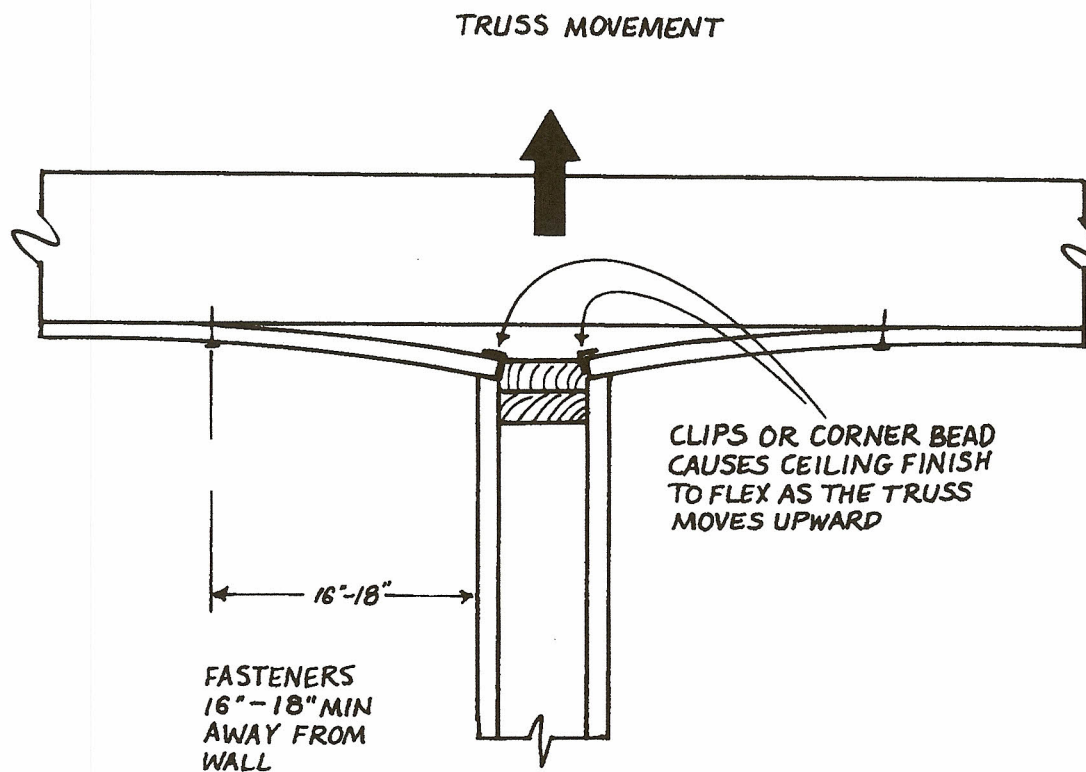


Figure 68. Ceiling-Floor Partition Separation

APPENDIX

1. *Wood Frame Construction Manual for One- and Two-Family Dwellings*, American Forest & Paper Association, 1111 19th Street, N.W., Suite 800, Washington, D.C. 20036.
2. *American Softwood Lumber Standard, PS 20-99*; U.S. Dept. of Commerce, National Institute of Standards and Technology, U.S. Government Printing Office, Washington, D.C. 20402.
3. *National Design Specification for Wood Construction*, American Forest & Paper Association, 1111 19th Street, N.W., Suite 800, Washington, D.C. 20036.
4. *Span Tables for Joists and Rafters*, American Forest & Paper Association, 1111 19th Street, N.W., Suite 800, Washington, D.C. 20036.
5. *Plank and Beam Framing for Residential Buildings- Wood Construction Data No. 4*, American Forest & Paper Association, 1111 19th Street, N.W., Suite 800, Washington, D.C. 20036.
6. *Permanent Wood Foundation System-Basic Requirements, Technical Report No. 7*, American Forest & Paper Association, 1111 19th Street, N.W., Suite 800, Washington, D.C. 20036.
7. *Permanent Wood Foundation Design and Construction Guide*, Southern Forest Products Association, P. O. Box 641700, Kenner, LA 70064.
8. *Design of Wood Structures for Permanence-Wood Construction Data No. 6*, American Forest & Paper Association, 1111 19th Street, N.W., Suite 800, Washington, D.C. 20036.
9. *Recommendations for Installing and Finishing Wood and Hardboard Siding Over Rigid Foam Sheathing*, American Forest & Paper Association, 1111 19th Street, N.W., Suite 800, Washington, D.C. 20036.
10. *U.S. Product Standard PS1-95 Construction and Industrial Plywood*, APA-The Engineered Wood Association, P.O. Box 11700, Tacoma, Washington, 98411.
11. *Basic Hardboard ANSI/AHA Standard A135.4*, American Hardboard Association, 1210 W. Northwest Hwy, Palatine, IL 60067.
12. *Research Report 82-2: Ceiling-Floor Partition Separation in Light Frame Construction*, Truss Plate Institute, 583 D'Onofrio Dr., Madison, WI 53719.
13. *Partition Separation Prevention and Solutions*, Wood Truss Council of America, 6300 Enterprise Lane, Madison, WI 53719

**American Forest & Paper Association
American Wood Council
1111 19th Street, NW
Suite 800
Washington, DC 20036
Phone: 202-463-4713
Fax: 202-463-2791**